



Instrument Expert
Original factory
packaging
www.keruiyiqi.cn



CozIR[®]-LP3 Evaluation Board User Guide

TABLE OF CONTENTS

INTRODUCTION	4
USB DRIVER	5
SOFTWARE INSTALLATION	5
INSTALLING THE SENSOR.....	5
EVALUATION BOARD CONCEPT	6
STANDALONE OPERATION.....	8
SENSOR POWER SUPPLY.....	9
Method 1 - External Power Supply	9
Method 2 - USB Power Supply	9
Method 3 - Variable External Power Supply	10
SENSOR POWER CONSUMPTION MEASUREMENT	12
ENVIRONMENTAL CONDITION MONITORING.....	12
EVALUATION BOARD BUTTONS, JUMPERS AND LED INDICATORS.....	12
SOFTWARE USER INTERFACE	13
RUNNING THE SOFTWARE.....	14
SENSOR SELECTION	15
CO₂ SENSOR MEASUREMENT.....	16
UART Communications Mode.....	17
I²C Communications Mode	17
OTHER ENVIRONMENTAL SENSORS	18
GRAPHING SENSOR DATA	19
CURRENT MEASUREMENT.....	20
ZERO-POINT SETTING THE SENSOR	21
ZERO IN NITROGEN	21
ZERO IN AMBIENT CONDITIONS	22
ZERO IN A KNOWN GAS CONCENTRATION.....	22
AUTO-ZERO FUNCTION	22
AUTO-ZERO INTERVALS.....	22
AUTO-ZERO LEVEL.....	23
PRESSURE COMPENSATION.....	24
DIGITAL FILTER SETTING	25
SENSOR COMMUNICATIONS	26
DATA DISPLAY	27
DATALOGGING.....	29

TERMINAL VIEW	31
TERMINAL VIEW – UART READ	32
TERMINAL VIEW – UART WRITE.....	33
TERMINAL VIEW – I²C WRITE	34
TERMINAL VIEW – I²C READ.....	35
MECHANICAL DIAGRAM.....	37
IMPORTANT NOTICE	38
ADDRESS	38
REVISION HISTORY.....	39

INTRODUCTION

This evaluation board is designed to provide a fast and easy start for evaluation of the GSS CozIR[®]-LP3 sensor. The evaluation board brings several interfaces and interconnections shown in Figure 1.

The CozIR[®]-LP3 Evaluation Board is designed to allow the user to evaluate all the hardware and software functions of the sensor. This manual provides information about the board's interconnections, jumper settings, communications, and debug interfaces.

The sensor can be controlled by a PC application via the USB interface, or standalone and controlled externally via connections to the sensor on the evaluation board.

The sensor and other supporting electronics can be evaluated using a PC software application. This provides the user with a graphical user interface to all the main functions of the sensor, as well as a terminal mode, allowing the user to write and read data directly from the sensor registers.

As well as evaluating the CO₂ sensor, the software application allows the user to monitor and store other environmental conditions such as pressure, relative humidity and temperature.

The evaluation board also has the capability to measure the current consumption of the sensor in any of its operating modes, allowing the use to accurately assess real world power use over time.

Alternatively, the sensor can be completely separated from all the other electronics on the evaluation board and controlled directly by the user via edge connectors. All data, control and GPIO pins of the sensor can be connected to connectors, J3, J4 and J5. Power is provided via a separate edge power connector (J2), via USB (J1), or directly via header (J5).

For more technical information on the sensor, download the appropriate data sheet from here: <https://www.gassensing.co.uk/products/>

USB DRIVER

To interface to a PC, the evaluation board requires a USB-A to USB-Mini B cable and a USB driver to function correctly. Recent versions of Windows will automatically identify and install the USB driver when you plug in the lead.

If the USB driver is not installed, or the evaluation board will not connect to a COMM port, please download the USB driver from the FTDI website:

<https://www.ftdichip.com/Drivers/VCP.htm>

Choose “VCP Drivers” and select the correct driver for your operating system.

SOFTWARE INSTALLATION

The GSS evaluation board software is available direct from the GSS web site. Download the .zip file to your computer. Unzip and click on **Setup.exe** and follow the instructions on the screen.

INSTALLING THE SENSOR

The sensor needs to be connected to the board. Rotate the fixing cams out of the way to allow insertion of the sensor. When the sensor is correctly seated on the pin headers, rotate the cams into place, clamping the sensor into place.

Insert the sensor before applying power to the board or connecting the USB interface. Refer to figure 2 on the following page of this user manual to determine the correct sensor orientation.

EVALUATION BOARD CONCEPT

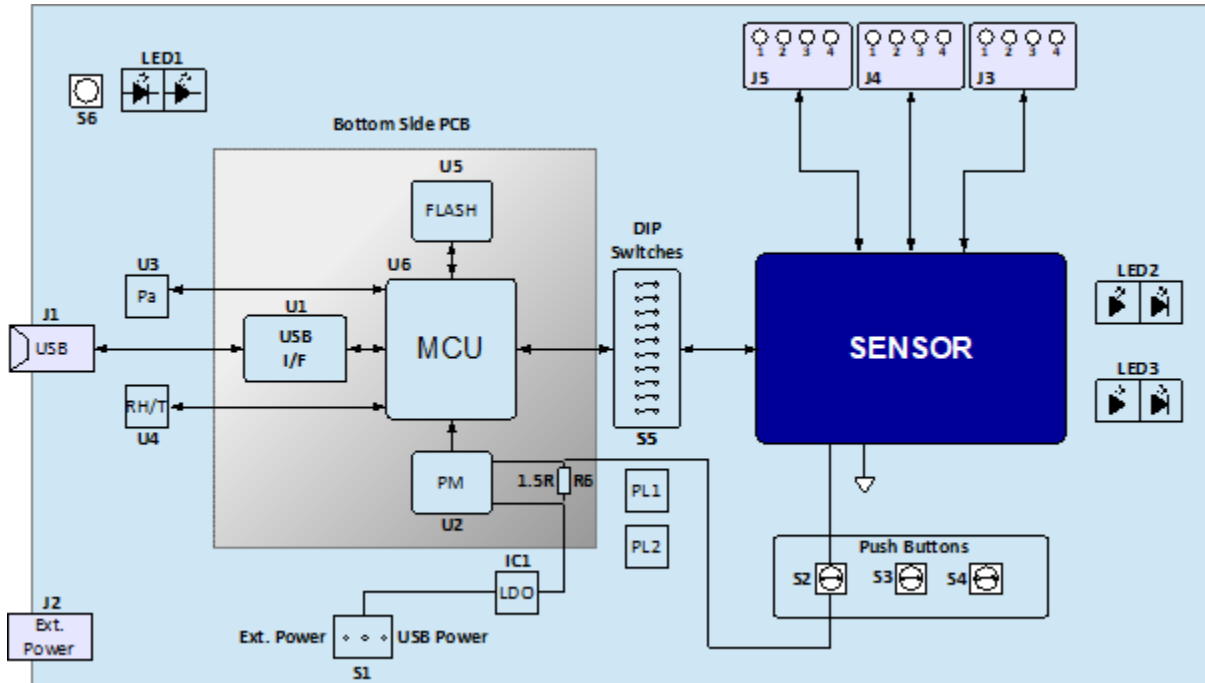

Figure 1: Evaluation Board Key Components

The evaluation board consists of a USB interface device, which connects to an on-board micro-controller. The on-board microcontroller connects to the sensor using either its UART or I²C interface. The interface mode is user selectable.

The microcontroller also interfaces to the environmental monitoring sensors. The board comes with temperature, humidity, and pressure sensors.

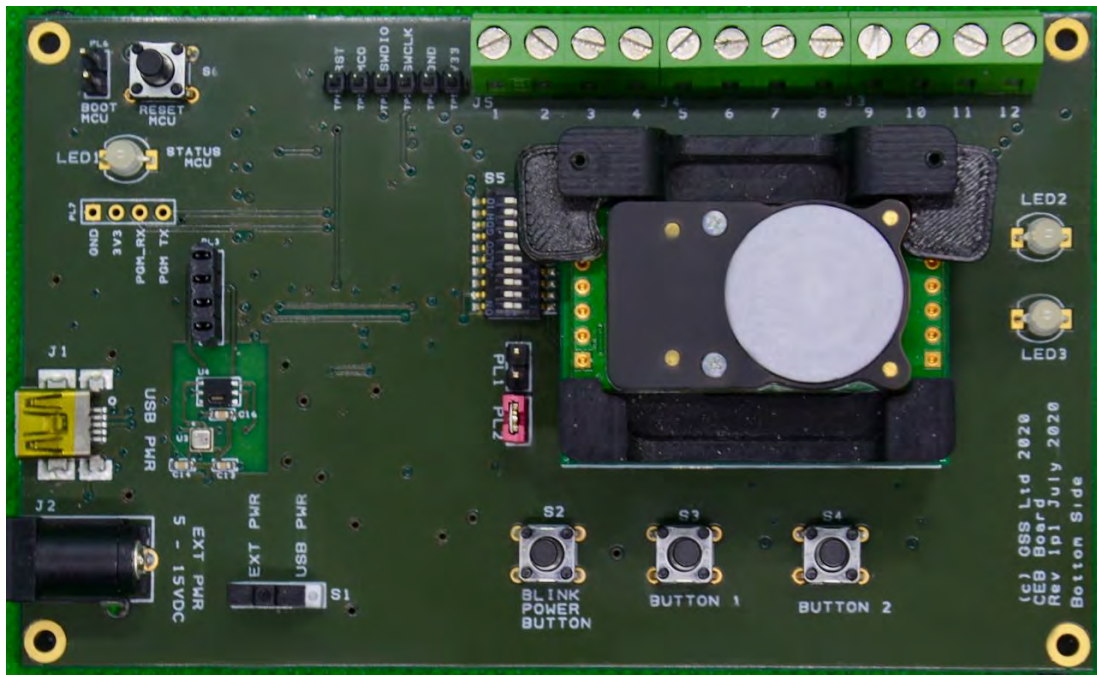

Figure 2: Top Side Evaluation Board

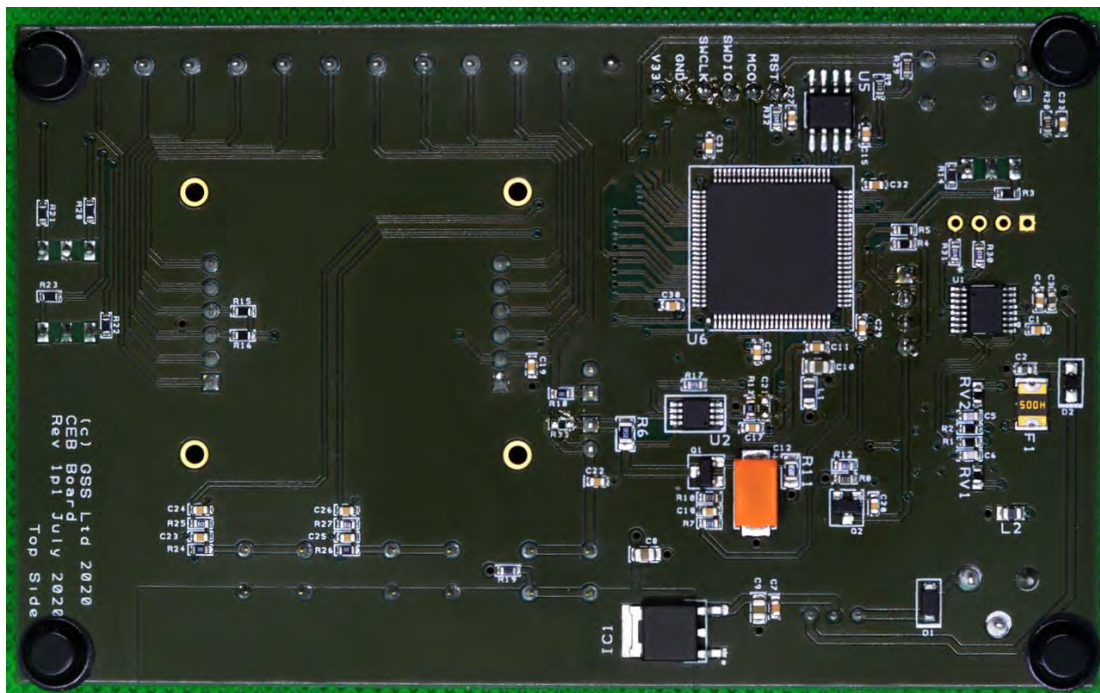

Figure 3: Bottom Side Evaluation Board

STANDALONE OPERATION

The sensor can be completely isolated from the rest of the evaluation board electronics. This allows the user to conveniently control the sensor directly via edge connectors J3, J4 and J5. To operate in this manner, the DIP switches (S5) must be set to isolate the sensor from the microcontroller by putting them into the off position.

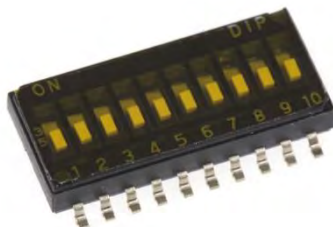

Figure 4: DIP Switches (S5, shown in OFF position)

The evaluation board is shipped with the DIP switches set **ON** (see label on switch) to connect the sensor to the on-board microcontroller by default. To isolate the sensor from the on-board microcontroller, set the switches to **OFF**. Power supply connections to the sensor are described in the following section.

The sensor switch connections on the DIP switches are listed below.

SWITCH POSITION	NAME	TYPE	DESCRIPTION
1	Rx_In	Digital Input	UART Receive Input
2	Tx_Out	Digital Output	UART Transmit Output
3	NC	Unused	Do not connect (For internal use only)
4	PWR_ON	Digital Input	Sensor Power On Enable pin. - Power on – High - Power off – Low
5	ALARM	Digital Output	Alarm Output
6	READY	Digital Output	Data ready pin. Pulsed high when data ready
7	I2C_SDA	Digital Input/Output	I ² C serial data input/output. Pull-up resistor to VDD is provided on the evaluation board.
8	I2C_SCL	Digital Input	I ² C serial clock input. Pull-up resistor to VDD is provided on the evaluation board.
9	I2C_ENABLE	Digital Input	Set low for I ² C interface mode. Leave floating to select UART interface mode. Pin status detected at power on.
10	PWM_RS485	Digital Output	PWM Output

SENSOR POWER SUPPLY

If the sensor is to be evaluated in isolation and separately from the evaluation board USB interface and software, it must be provided with power. There are three methods to provide power to the sensor. Note the sensor must be powered via the USB interface if the GSS evaluation software is to be used.

Method 1 - External Power Supply

The sensor can be supplied from an external power source via the connector (J2). This connector can accept either a 2.5mm or 2.1mm standard DC 5V power supply barrel plug. This drives a low noise low drop out (LDO) regulator, which supplies the sensor via a FET switch. The state of the FET switch is controlled by the state of the PWR_On pin, accessed via connector J5, pin 4.

The LDO regulator provides a stable 3.3V output to the sensor. To enable this mode of operation, switch S1 should be set to external power (EXT PWR). The LDO input voltage range is a nominal 5V to 15V.

Method 2 - USB Power Supply

Power can be provided from a USB source. Plug J1 into a USB power source and set switch S1 to USB power (USB PWR), see picture below. This drives a low noise low drop out (LDO) regulator, which supplies the sensor via a FET switch. The state of the FET switch is controlled by the state of the PWR_On pin, accessed via connector J5, pin 4. The LDO regulator provides a stable 3.3V output to the sensor.

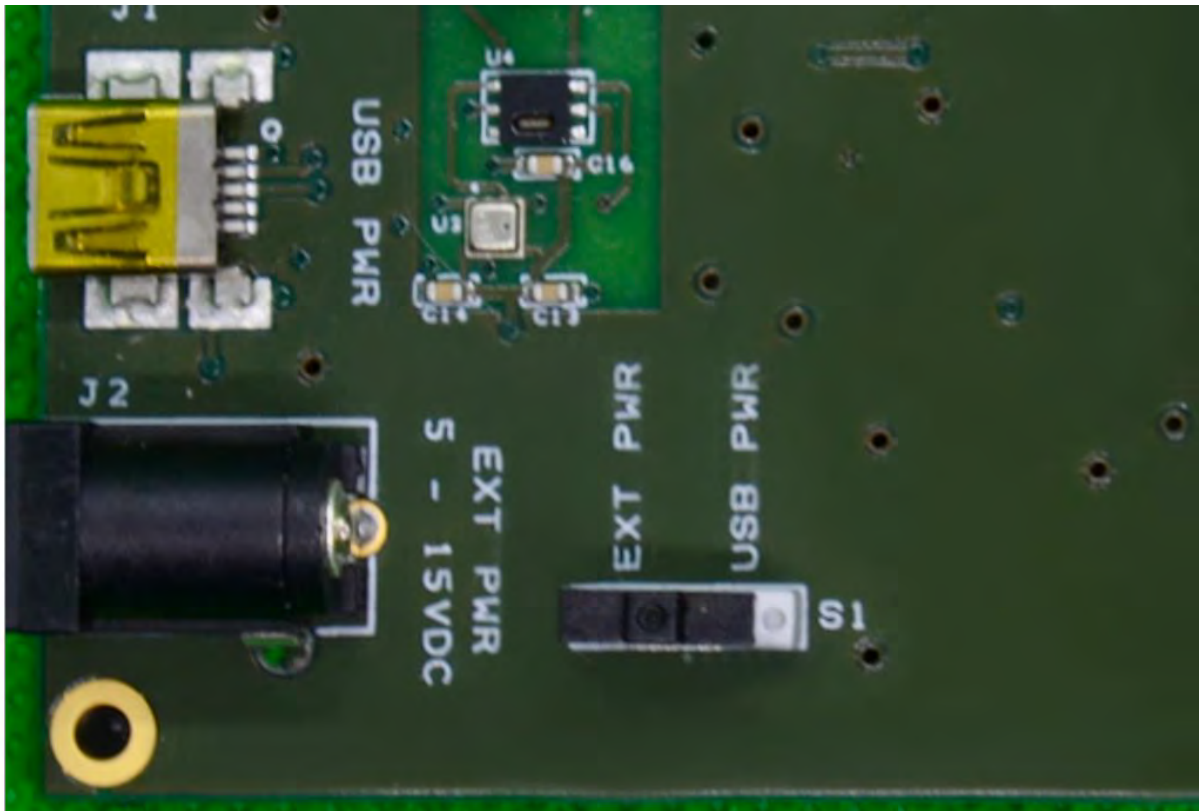

Method 3 - Variable External Power Supply

The user can also drive the sensor directly with an external power supply, bypassing the on-board low noise LDO and FET switch. This allows the user to evaluate the behaviour of the sensor with different supply voltages or power sources. To enable this mode of operation, the following settings need to be configured.

Connector/Jumper	Setting	Sensor Connection
J5, pin 1	Connect to external GND	GND
J5, pin 2	Connect to external VDD	VDD
PL1	Remove jumper. Isolates sensor from rest of the evaluation board	
PL2	Remove jumper. Isolates sensor from rest of the evaluation board	-

The evaluation board has pull-up resistors for the I²C serial data input/output lines in each of these modes. They pull-up to either the on-board 3.3V supply, or the external VDD on J5, pin 2.

All the sensor connections are enumerated on connectors, J3, J4 and J5. For a full description of the sensor connections and functions, please refer to the latest version of the data sheet at, <https://www.gassensing.co.uk/products/>.

J3

PIN	NAME	TYPE	DESCRIPTION
1	I2C_SCL	Digital Input	I ² C serial clock input. Open drain, external 3.3kΩ resistor pulled high to VDD required
2	I2C_SDA	Digital Input/Output	I ² C serial data input/output. Open drain, external 3.3kΩ resistor pulled high to VDD required
3	Tx_Out	Digital Output	UART Transmit Output
4	Rx_In	Digital Input	UART Receive Input

J4

PIN	NAME	TYPE	DESCRIPTION
1	ALARM	Digital Output	Alarm Output
2	READY	Digital Output	Data ready pin. Pulsed high when data ready
3	PWM_RS485	Digital Output	PWM Output
4	I2C_ENABLE	Digital Input	Set low for I ² C interface mode. Leave floating to select UART interface mode. Pin status detected at power on.

J5

PIN	NAME	TYPE	DESCRIPTION
1	GND	Supply	Sensor ground
2	VDD	Supply	Sensor supply voltage
3	NC	Unused	Do not connect (For internal use only)
4	PWR_ON	Digital Input	Sensor Power on Enable pin - Power on – High - Power off – Low If unused, connect to VDD

SENSOR POWER CONSUMPTION MEASUREMENT

The sensor evaluation board contains circuitry to allow the user to accurately measure sensor current consumption. A high-precision, high-side current-sense amplifier is used to measure the current through a 1.5ohm resistor R6. The signal is digitised by the on-board microcontroller.

The application software displays the current draw of the sensor over a measurement cycle. The sensor power consumption measurement application operates when using sensor power method 2. It cannot be used when powering the sensor using method 1 or 3.

ENVIRONMENTAL CONDITION MONITORING

In addition to CO₂ measurement, the sensor evaluation board comes with the ability to measure relative humidity, temperature and pressure in real time. These functions operate independently of the CO₂ sensor. The application software displays and can store these conditions. The evaluation board must be powered either via the USB interface (method 2), or the external power supply (method 1).

EVALUATION BOARD BUTTONS, JUMPERS AND LED INDICATORS

BUTTON	DESCRIPTION
S1	USB power or external power
S2	Blink mode. Cuts power to the sensor with CozIR®-Blink. Unused for CozIR®-LP3.
S3	Unused
S4	Unused
S5	Evaluation board micro to sensor interface
S6	Reset MCU

JUMPER	DESCRIPTION
PL1	No fit for CozIR®-LP3
PL2	Allows sensor to be isolated from USB or S1 power connections. Remove jumper if using external power via J5

LED	DESCRIPTION
LED1	Green. Shows Evaluation board is running
LED2	Green. Shows transmission of data to the board in UART mode Red. Shows transmission of data to the board in I ² C mode
LED3	Green. Shows transmission of data from the sensor in UART mode Red. Shows transmission of data from the sensor in I ² C mode

SOFTWARE USER INTERFACE

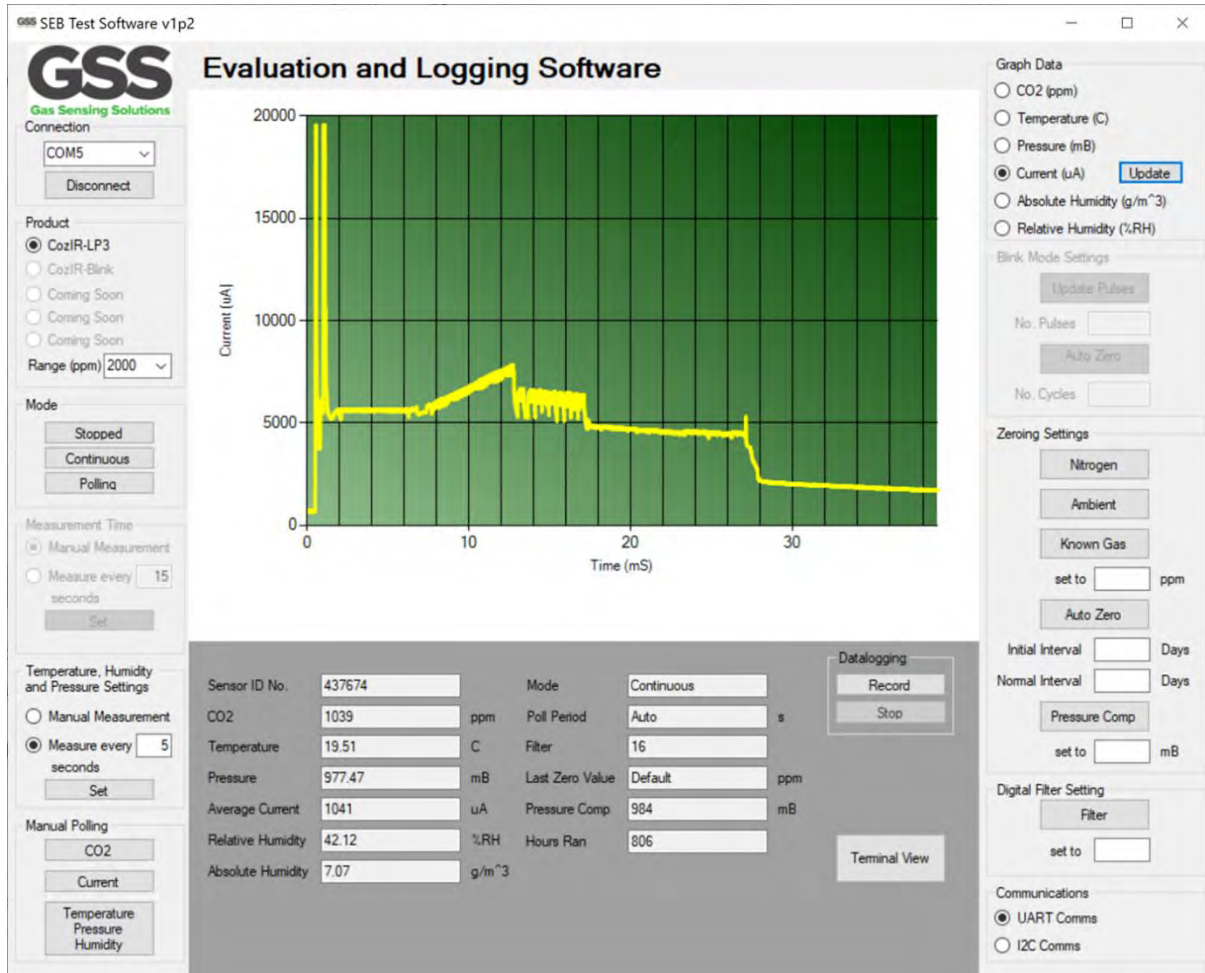

All the main sensor and evaluation board functions are controlled through a single user interface, displayed above. Hovering over a button will display the tips for that function.

RUNNING THE SOFTWARE

The software may start automatically after installation. If it does not, you can start it from the “Program” Menu in the Start Menu. Look for the filename **GSS Customer Evaluation Board**. The opening screen is below.

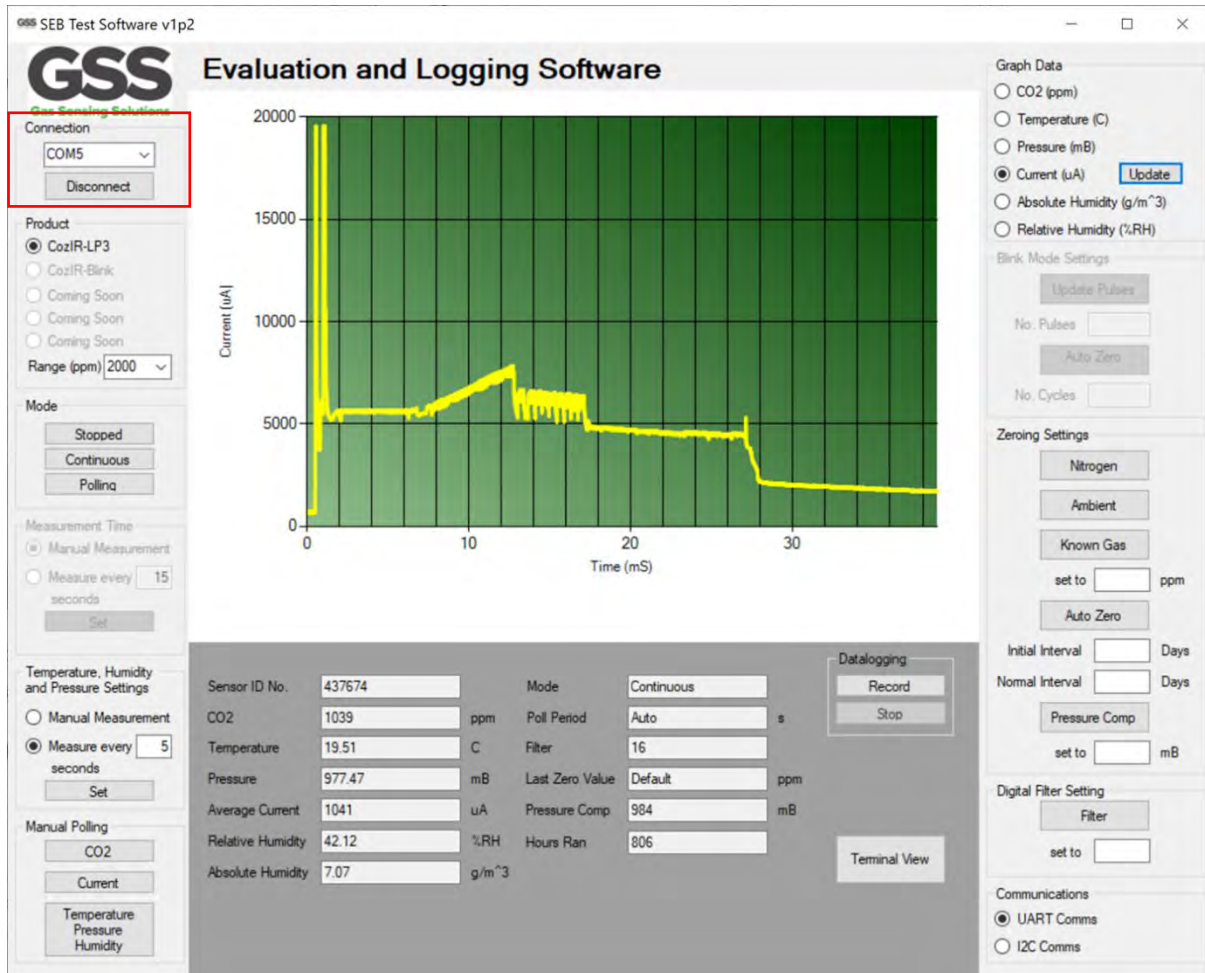

To connect to the sensor, select the correct COM port from the drop-down Connection list, and click the **CONNECT** button. The drop-down list will only show ports with active devices attached.



If you do not know the appropriate port select “device manager” on your PC, select Ports, and unplug the SEB and then plug back in. The Com port will show up when the board is plugged in.

SENSOR SELECTION

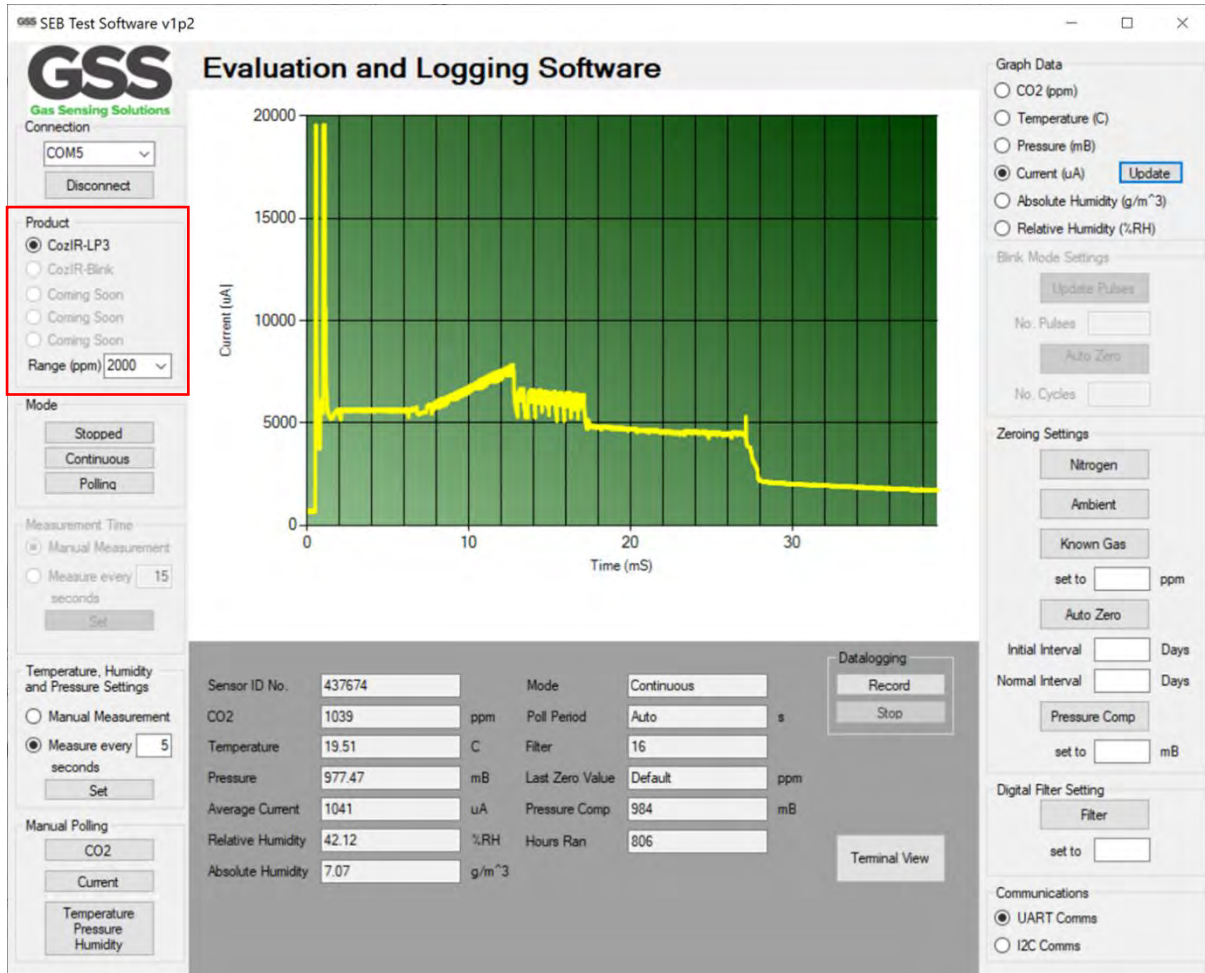

The screenshot shows the 'Evaluation and Logging Software' interface. On the left, the 'Product' dropdown is set to 'CozIR-LP3' and the 'Range (ppm)' is set to '2000'. The 'Mode' is set to 'Continuous'. The 'Measurement Time' is set to 'Manual Measurement' with a 'Measure every' interval of 5 seconds. The 'Temperature, Humidity and Pressure Settings' are also visible, with 'Manual Measurement' selected and a 'Measure every' interval of 5 seconds. The 'Manual Polling' section has 'CO2', 'Current', and 'Temperature Pressure Humidity' buttons. The 'Datalogging' section has 'Record' and 'Stop' buttons. The 'Terminal View' button is also present.

The central graph shows 'Current (uA)' on the y-axis (0 to 20000) and 'Time (mS)' on the x-axis (0 to 30). The graph displays a sharp initial spike in current, followed by a steady rise and then a slight decline, indicating the sensor's response to a measurement.

On the right side, the 'Graph Data' section has radio buttons for 'CO2 (ppm)', 'Temperature (C)', 'Pressure (mB)', 'Current (uA)', 'Absolute Humidity (g/m^3)', and 'Relative Humidity (%RH)'. The 'Current (uA)' option is selected. Below this, there are 'Blink Mode Settings' and 'Zeroing Settings' sections, including buttons for 'Nitrogen', 'Ambient', and 'Known Gas', along with input fields for 'set to' values and 'Auto Zero' buttons. The 'Digital Filter Setting' section has a 'Filter' button and a 'set to' field. The 'Communications' section has radio buttons for 'UART Comms' (selected) and 'I2C Comms'.

Select the correct sensor type and the full-scale range (CO₂ ppm) of the sensor. The sensor should automatically start to take CO₂ measurements after 2-3 seconds. These measurements are shown graphically in the middle of the screen.

The default operating mode of the sensor on the evaluation board is set to continuous measurement using the UART interface.

Additionally, the power LED1 will illuminate green showing the sensor evaluation board is running.

CO₂ SENSOR MEASUREMENT

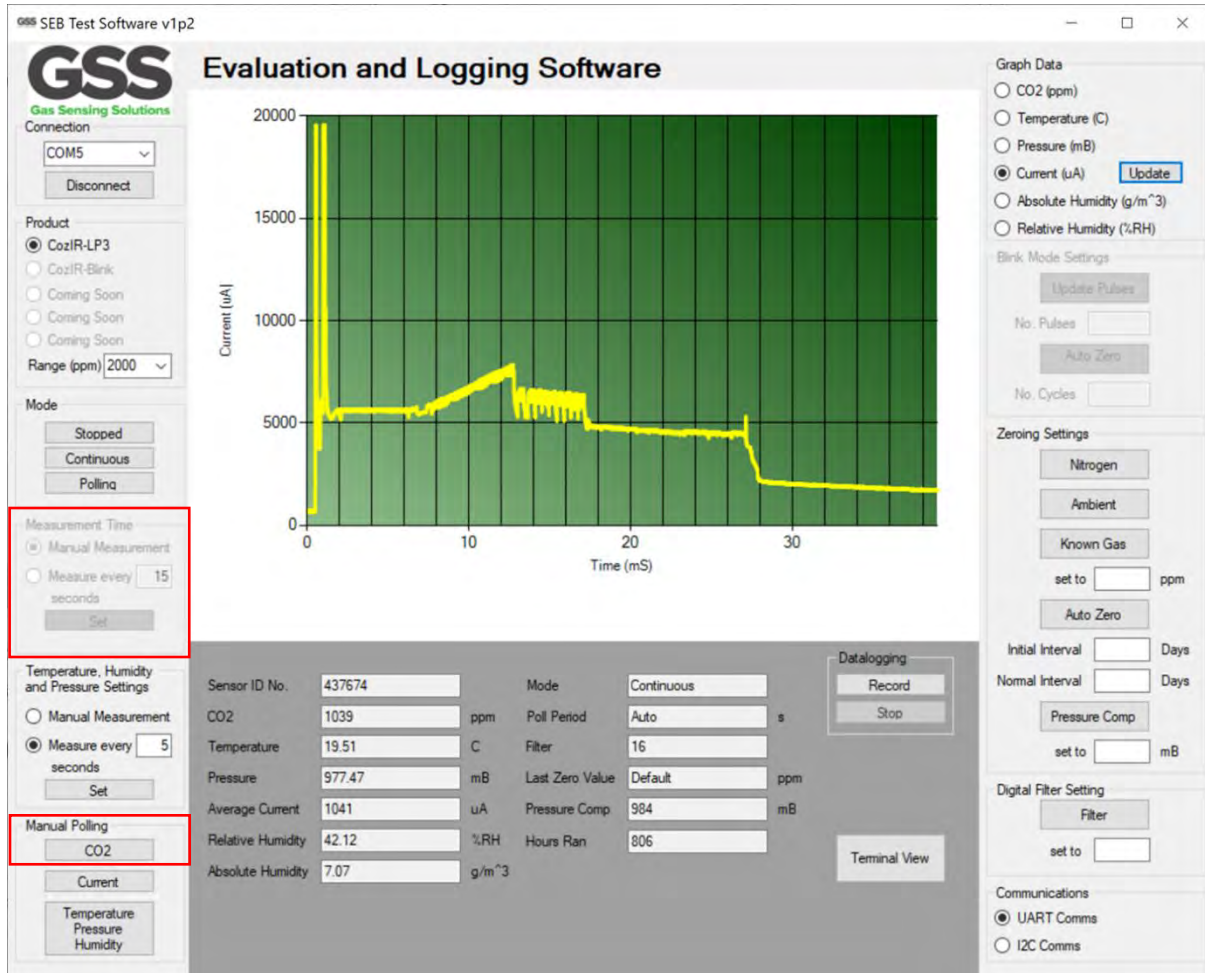

GSS CO₂ sensors have several measurement modes. The number and type of modes available depend on the sensor and the digital interface mode. Select the 'Mode' using one of the 3 buttons.

Stopped: All measurements are stopped. The sensor is still capable of reading and writing to the control interface. Some commands are not be available in this mode, please see the datasheet.

Continuous: Measurements running continuously and reading sent at a fixed rate of 2 per second.

Polling: Measurements running in the background. Readings on command (manual) or at a programmable rate (<2 per second).

UART Communications Mode

When the UART interface is chosen, all three measurement modes are available. By default, except for the Blink range of products, after power-on, the sensor will automatically start taking measurements in 'Continuous' mode, at 2 readings per second.

To stop taking measurements, click on 'Stopped'. To re-start taking measurements, click on 'Continuous' mode.

To take readings at a scheduled time period, click on 'Polling'. This allows the user to take one reading at a time or to pre-set their own reading period. In this mode, measurements are still running in the background. The reading will be updated at the polling rate.

To take one reading at a time, set 'Measurement Time' to Manual Measurement.

A CO₂ reading is made by clicking on the 'Manual Polling' CO₂ button. The user interface in the lower centre of the screen will update each sensor value when 'Manual Measurement' is clicked.

To take readings at a scheduled time period, click on 'Polling' and change 'Measurement Time' to 'Measure every 5 seconds' and click on 'Set'. This allows the user to pre-set their own read period.

The user interface in the lower centre of the screen will update the CO₂ sensor value at the scheduled period.

When in UART mode, LED 2 will flash green momentarily to show transmission of data to the sensor, and LED 3 will flash green momentarily to show data transmission from the sensor.

I²C Communications Mode

When the I²C interface is chosen, two measurement modes are available. By default, the sensor will take one reading at a time using 'Manual Polling'. Alternatively, the user interface can be configured to take a reading using the programmable time-period. Click on the 'Measure every 10 seconds' box, set the measurement period in seconds and click on 'Set'.

The user interface in the lower centre of the screen will update the CO₂ sensor value at the scheduled period.

When in I²C mode, LED 2 will flash red momentarily to show transmission of data to the sensor, and LED 3 will flash red momentarily to show data transmission from the sensor.

OTHER ENVIRONMENTAL SENSORS

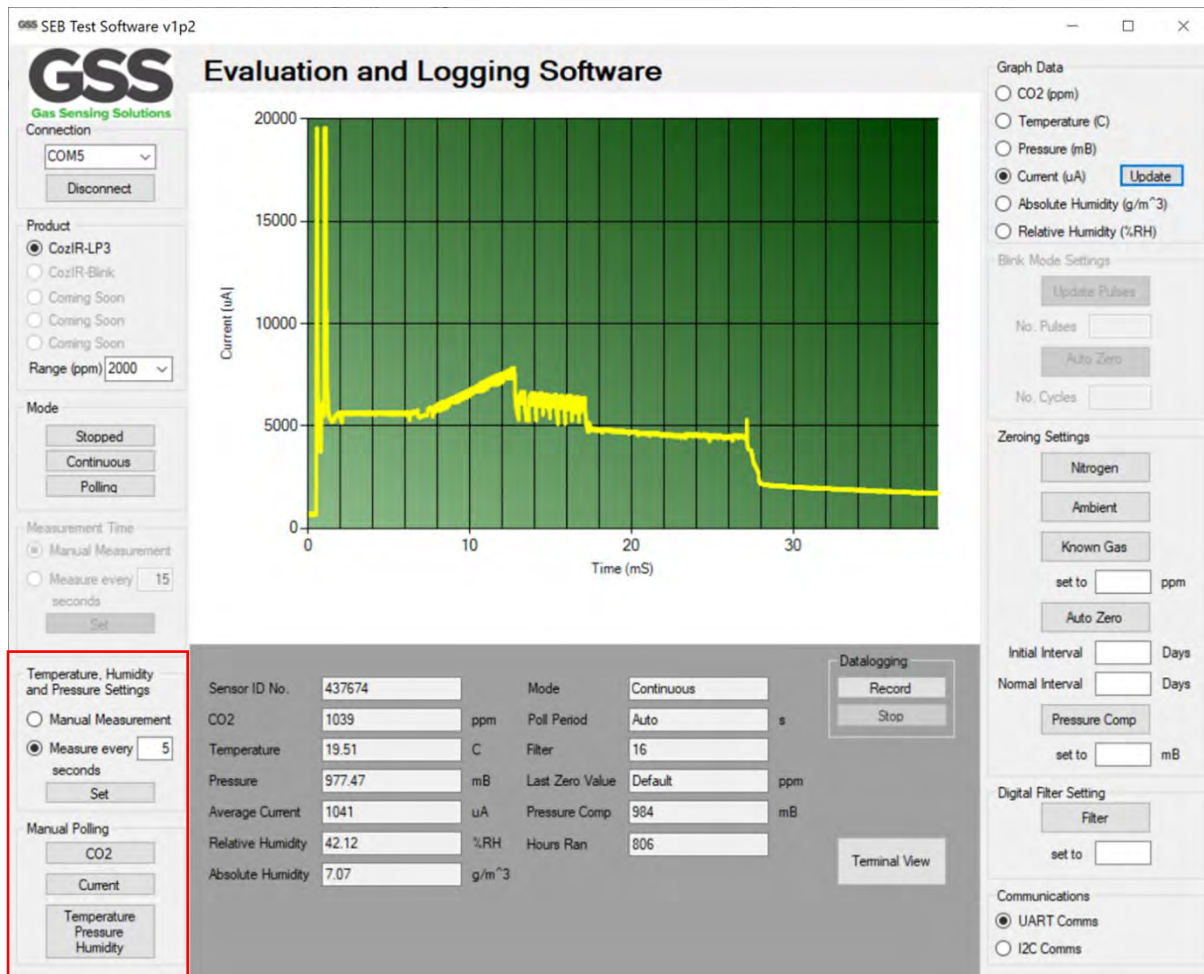

The evaluation board also contains on-board temperature, humidity, pressure and current sensors. These can be set to take measurements automatically at a pre-set period or set to take readings manually. Note the time period can be set independently of the CO₂ sensor read period.

For manual readings, click 'Manual Measurement'. Manual readings can be taken for each sensor including the CO₂ sensor by clicking on the relevant button. The user interface in the lower centre of the screen will update each sensor value when 'Manual Measurement' is clicked.

Alternatively, the sensors can be programmed to take readings continuously at the rate set in the dialogue box. Click on the 'Measure every 5 seconds box', set the measurement period and click on 'Set'.

The user interface in the lower centre of the screen will update every time period.

The current measurement function behaves slightly differently to the other sensors. The 'Average Current' displayed in the lower centre of the screen is the average current consumed by the sensor over a single reading period.

If the sensor is set to 'Continuous Mode' or 'Polling' Mode, where the sensor is taking a measurement every 0.5s, the average current is defined over the 0.5s period.

GRAPHING SENSOR DATA

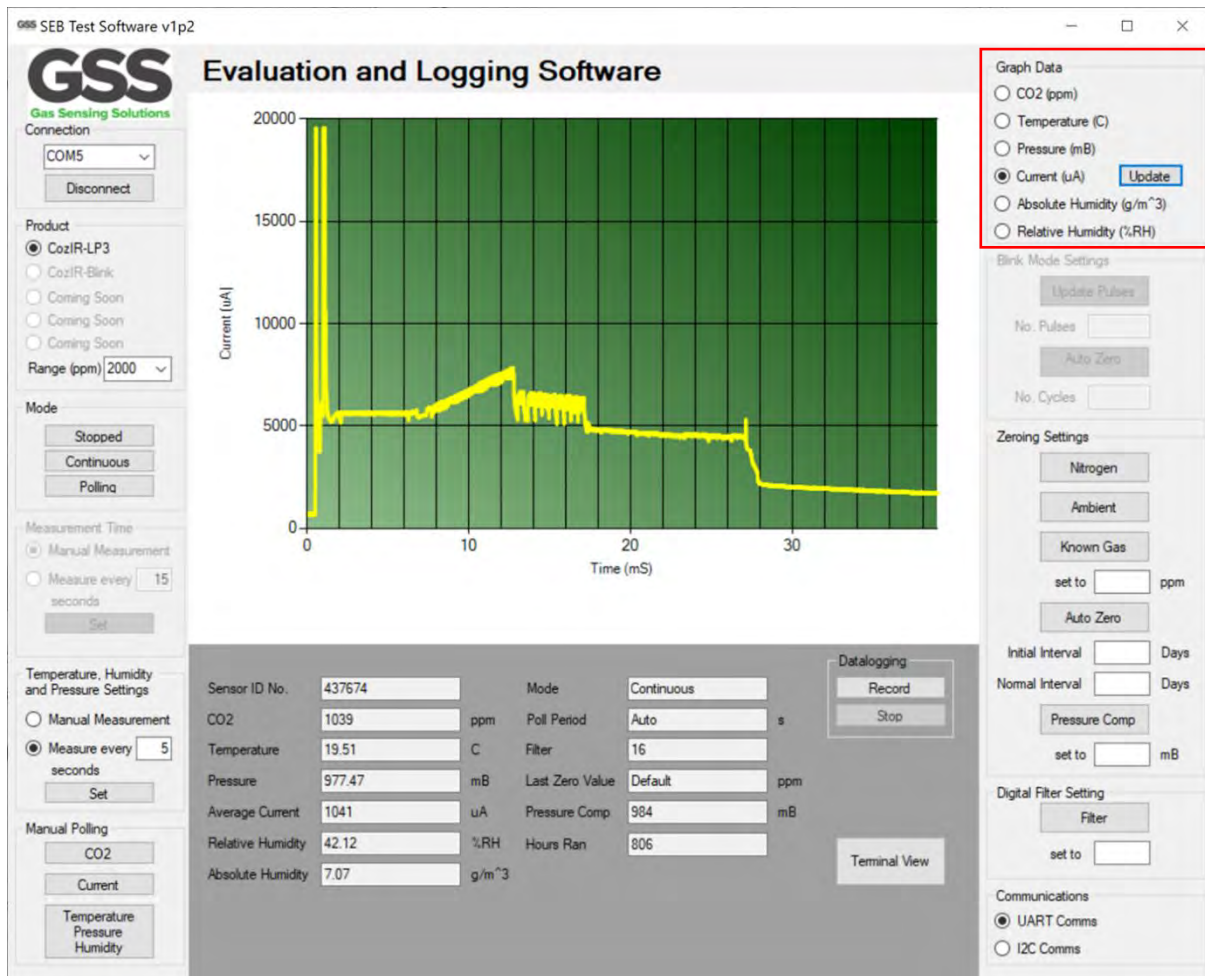

The screenshot displays the 'GSS Evaluation and Logging Software' interface. On the left, there are configuration panels for Connection (COM5), Product (CozIR-LP3), Mode (Continuous), and Measurement Time (Manual Measurement). The central graph plots 'Current (uA)' on the y-axis (0 to 20000) against 'Time (mS)' on the x-axis (0 to 30). A yellow line shows a sharp initial spike, followed by a steady rise to approximately 7500 uA at 15 mS, then a slight dip and stabilization around 5000 uA. On the right, the 'Graph Data' settings are highlighted with a red box, showing 'Current (uA)' selected and the 'Update' button. Below the graph, a data table provides real-time sensor readings:

Sensor ID No.	437674	Mode	Continuous
CO2	1039 ppm	Poll Period	Auto s
Temperature	19.51 C	Filter	16
Pressure	977.47 mB	Last Zero Value	Default ppm
Average Current	1041 uA	Pressure Comp	984 mB
Relative Humidity	42.12 %RH	Hours Ran	806
Absolute Humidity	7.07 g/m ³		

The user can graph sensor data. Click on the appropriate sensor box to graph the data in the upper central area of the user interface. Note, only one sensor can be graphed at a time.

The graph update rate is set to the measurement rate, defined by the 'Polling' or 'Continuous' Mode settings in the case of the CO₂ sensor, or by the Temperature, Humidity and Pressure settings.

When the current graph is enabled, the evaluation board will accurately measure and graph the current the sensor uses over the measurement period. This can be updated by clicking the 'Update' button or manually polling using the 'Current' button. The key activity period is displayed and the average current per reading cycle is shown in the output field in the lower half of the display.

For the CozIR®-LP3, where the sensor is updating measurements at 0.5 s intervals, the average current will be that consumed by the sensor over the whole 0.5s period.

CURRENT MEASUREMENT

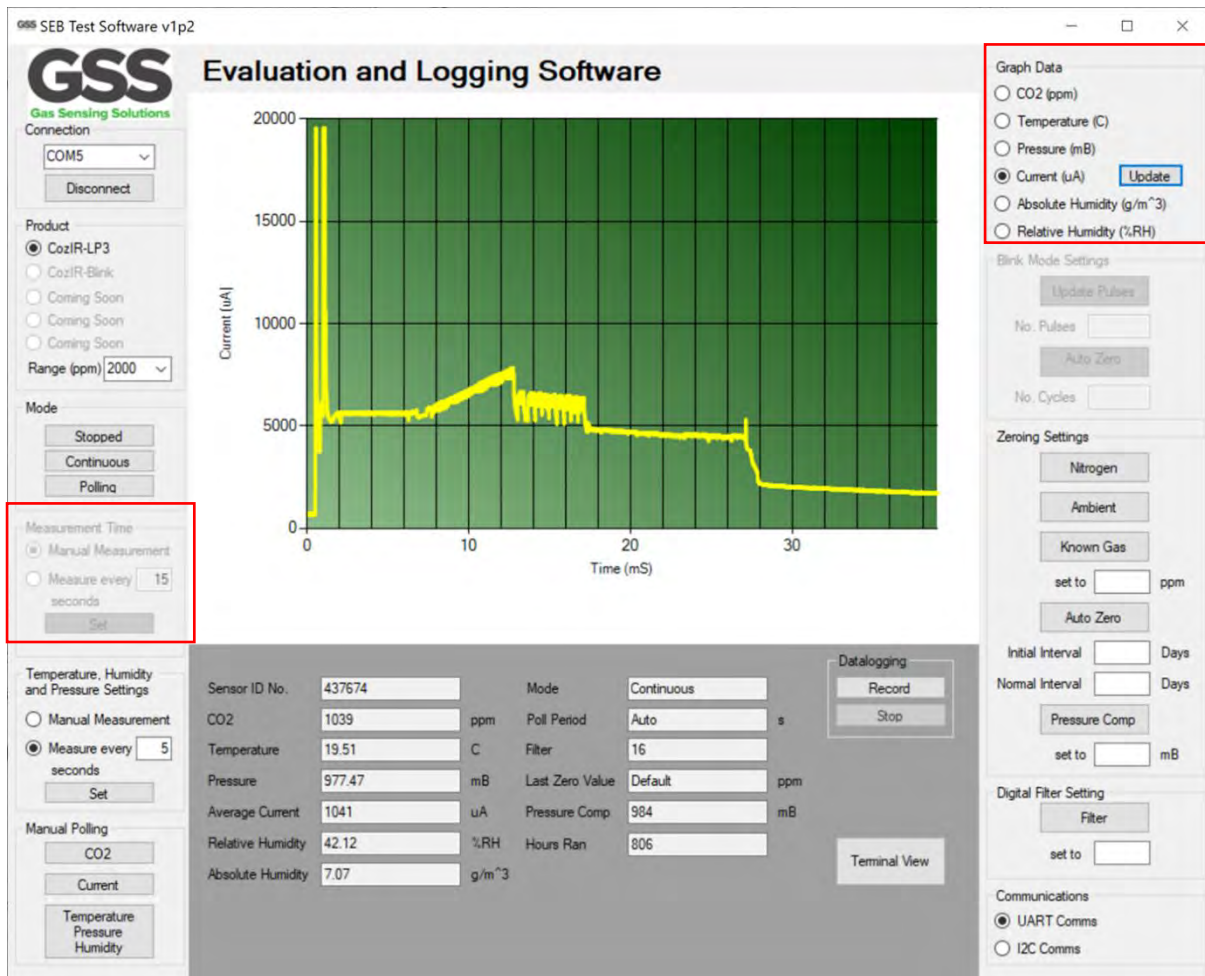

To measure current, the sensor must be in 'Manual Measurement' mode.

The current measurement function generates a real time graphical display of the current consumption of the sensor.

To measure average current, click on 'Update' Current (uA) in the Graph Data section.

The 'Average Current' displayed in the lower centre of the screen is the current consumed by the sensor over a complete 0.5s measurement cycle period.

ZERO-POINT SETTING THE SENSOR

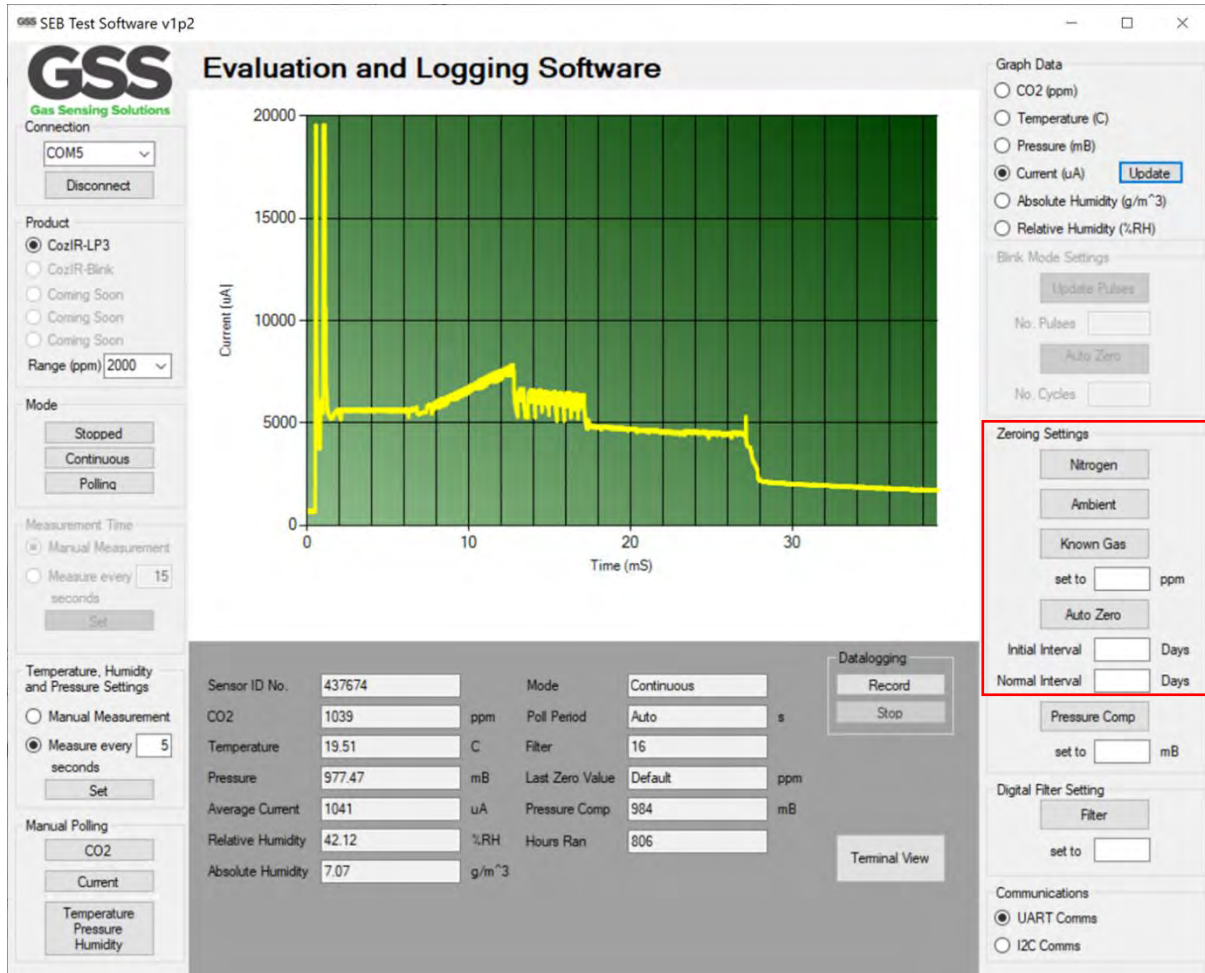

The screenshot shows the GSS SEB Test Software v1p2 interface. The main window is titled 'Evaluation and Logging Software'. It features a central graph showing 'Current (uA)' on the y-axis (0 to 20000) and 'Time (mS)' on the x-axis (0 to 30). The graph displays a yellow line representing the sensor's current over time. The line starts at 0, spikes to nearly 20000 uA at 0 mS, then drops to around 5000 uA. It then rises to a peak of approximately 7000 uA at 15 mS, before settling around 4000 uA and finally dropping to about 2000 uA at 30 mS.

On the right side of the interface, there is a 'Zeroing Settings' panel highlighted with a red box. It contains the following options:

- Nitrogen
- Ambient
- Known Gas
- set to ppm
-
- Initial Interval Days
- Normal Interval Days

Below the graph, there is a data table with the following information:

Sensor ID No.	437674	Mode	Continuous
CO2	1039 ppm	Poll Period	Auto s
Temperature	19.51 C	Filter	16
Pressure	977.47 mB	Last Zero Value	Default ppm
Average Current	1041 uA	Pressure Comp	984 mB
Relative Humidity	42.12 %RH	Hours Ran	806
Absolute Humidity	7.07 g/m ³		

There are a several methods available to the user to set the zero point of the sensor. In all cases, the best zero is obtained when the gas concentration is stable, and the sensor is at a stable temperature. Note the zero-point settings are not cumulative and only the latest zero-point setting is effective. For example, there is no benefit in zeroing in nitrogen, and then zeroing in a calibration gas. The sensor will store only the latest zero point.

ZERO IN NITROGEN

Place the sensor in nitrogen gas and allow time for the sensor to stabilise and the gas to be fully diffused into the sensor. Click on 'Nitrogen'. The sensor will be zeroed assuming a 0ppm CO₂ environment.

ZERO IN AMBIENT CONDITIONS

If there is no calibration gas or nitrogen available, the sensor zero-point can be set in fresh air. Ambient CO₂ concentrations in fresh air are typically 400ppm. Place the sensor in a fresh air environment and allow time for the sensor temperature to stabilise, and for the fresh air to be fully diffused into the sensor. If there is no value in the 'Set to' dialogue box, when 'Ambient' is clicked, the sensor will be zeroed assuming the ambient environment is 400ppm.

The CO₂ concentration fresh air zero level is programmable over a range from 0ppm to the full scale of the sensor. The software default is 400ppm as the fresh air CO₂ concentration value. However, the user can write a different fresh air value to the sensor if desired.

To write a different fresh air CO₂ concentration value to the sensor, set the CO₂ concentration value to the appropriate value by writing the value in the 'set to' box. Click on 'Ambient'.

ZERO IN A KNOWN GAS CONCENTRATION

Place the sensor in a known gas concentration, and allow time for the sensor temperature to stabilise, and for the gas to be fully diffused into the sensor. Set the CO₂ concentration value to the appropriate value by writing the value in the 'set to' box. Click on 'Known Gas'.

AUTO-ZERO FUNCTION

The sensor has a built-in auto-zeroing function. To function correctly, the sensor must be exposed to typical background fresh air levels (~400ppm) at least once during the auto-zero period. The auto-zero function uses the information gathered during these periods to re-zero. The sensor will reset the 'zero' level every time it does an auto-zero. Auto-zeroing is enabled by default. If the sensor is powered down, the auto-zero is reset to default fresh air value, 400ppm. The user can change this default value.

The auto-zero function works in the same way as the 'Ambient' command.

AUTO-ZERO INTERVALS

The auto-zero period can be programmed by the user. The sensor can be programmed to undertake an initial auto-zero after power-on. Thereafter, the auto-zero period can be set independently of the start-up auto-zero time. Note, the auto-zero settings are reset if the sensor is powered down. Write the 'Initial interval' and 'Normal Interval' period in the box and click on 'Auto Zero'.

AUTO-ZERO LEVEL

The background concentration will depend on sensor location. Ambient levels are typically in the range of 400ppm - 450ppm. The factory default is set to 400ppm. The user can change the background ambient level used for auto-zeroing. The value is stored in the sensor.

Typically, it is set to the same value as the ambient value, but it can also be set at a different level if desired. To write a different fresh air CO₂ concentration value to the sensor used for auto-zeroing, the command must be sent to the sensor manually using the software terminal mode. For more details on how to adjust the auto-zero fresh air CO₂ concentration value, see the full data sheet at <https://www.gassensing.co.uk/products/>.

PRESSURE COMPENSATION

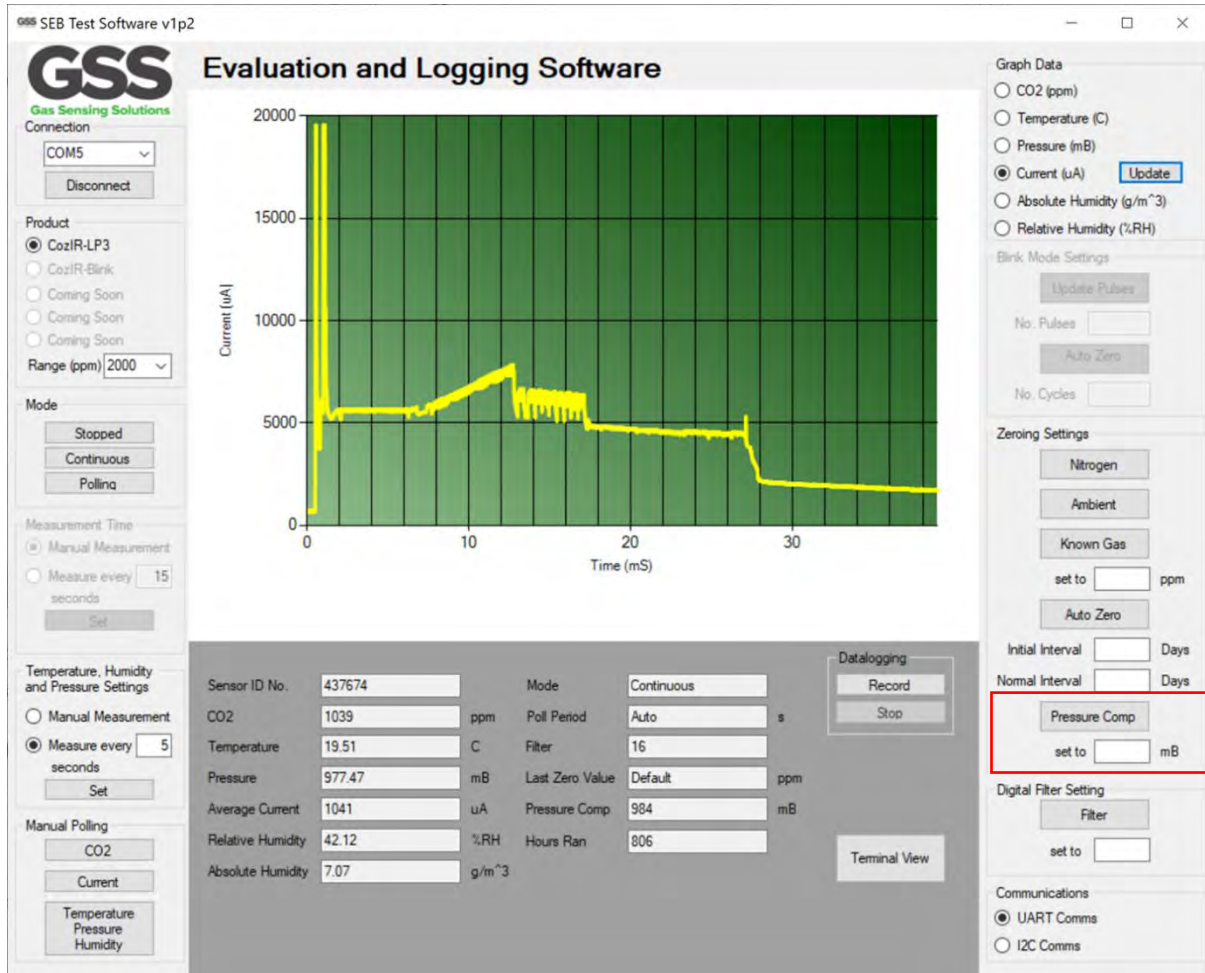

GSS SEB Test Software v1p2

Evaluation and Logging Software

Connection: COM5

Product: CozIR-LP3

Mode: Continuous

Measurement Time: Manual Measurement

Temperature, Humidity and Pressure Settings: Measure every 5 seconds

Manual Polling: CO2, Current, Temperature Pressure Humidity

Graph Data:

- CO2 (ppm)
- Temperature (C)
- Pressure (mB)
- Current (uA) Update
- Absolute Humidity (g/m³)
- Relative Humidity (%RH)

Blink Mode Settings:

- Update Pulses
- No. Pulses:
- Auto Zero
- No. Cycles:

Zeroing Settings:

- Nitrogen
- Ambient
- Known Gas
- set to ppm
- Auto Zero
- Initial Interval Days
- Normal Interval Days
- Pressure Comp
- set to mB

Datalogging:

- Record
- Stop

Sensor ID No.	437674	Mode	Continuous
CO2	1039 ppm	Poll Period	Auto s
Temperature	19.51 C	Filter	16
Pressure	977.47 mB	Last Zero Value	Default ppm
Average Current	1041 uA	Pressure Comp	984 mB
Relative Humidity	42.12 %RH	Hours Ran	806
Absolute Humidity	7.07 g/m ³		

Terminal View

GSS sensors are calibrated at a nominal 1013mbar. The CO₂ reading from the sensor will vary from the nominal output if the mean barometric pressure is different from the calibration setting.

It is possible to configure the sensor to correct for this effect by writing the actual or reference mean barometric pressure in mbar to the sensor. This can be done as part of the initial set up process or updated at any time during use. Write the decimal value in mbar into the dialogue box and click 'Pressure Comp'.

DIGITAL FILTER SETTING

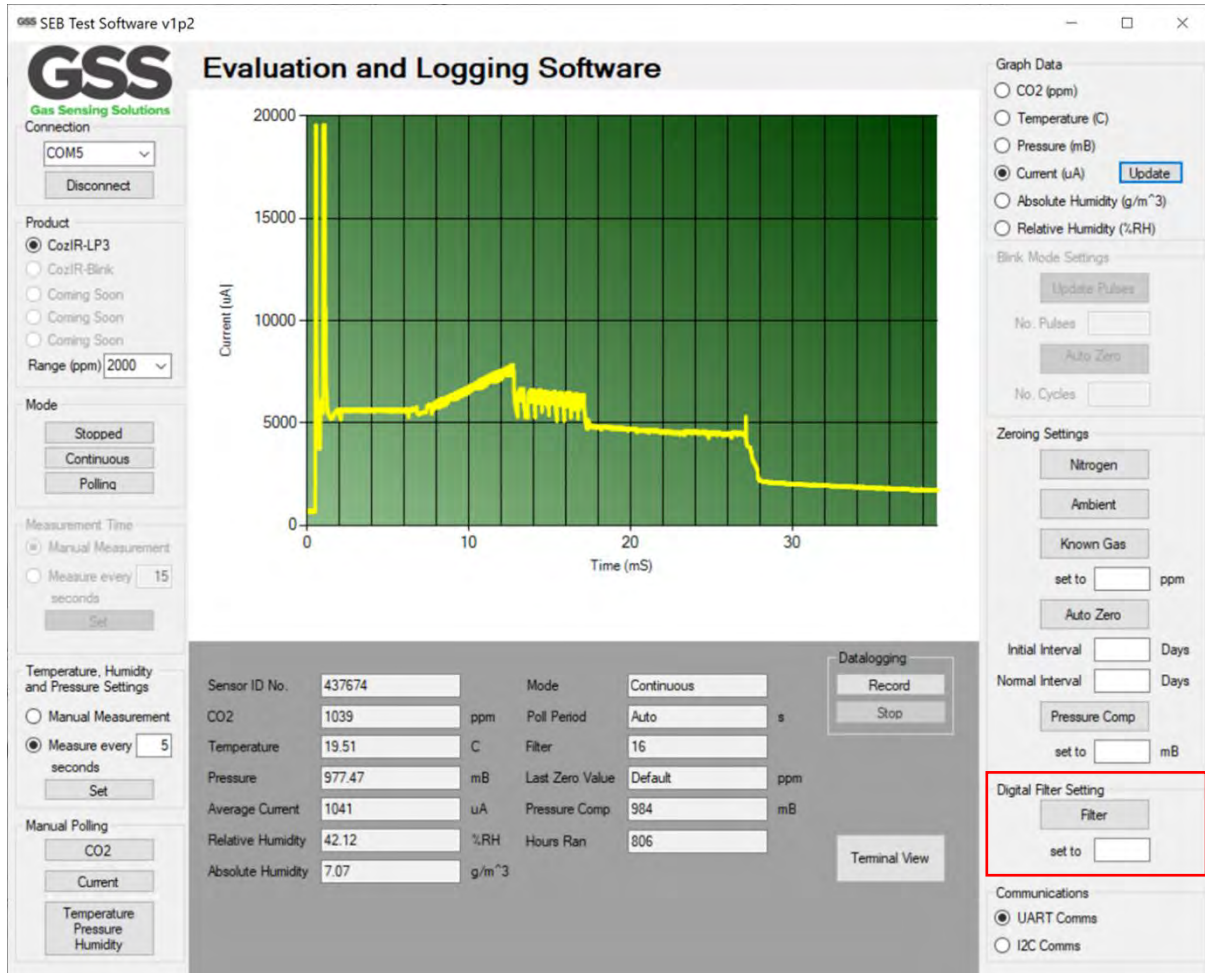

The screenshot displays the 'Evaluation and Logging Software' interface. The central graph shows a current response over time, with a sharp initial spike followed by a steady rise and then a gradual decline. The y-axis is labeled 'Current (uA)' ranging from 0 to 20000, and the x-axis is 'Time (mS)' ranging from 0 to 30. On the right side, the 'Graph Data' panel has 'Current (uA)' selected. Below it, the 'Digital Filter Setting' panel is highlighted with a red box, showing a 'Filter' button and a 'set to' input field. The bottom section of the interface contains a table of sensor data:

Sensor ID No.	437674	Mode	Continuous
CO2	1039 ppm	Poll Period	Auto s
Temperature	19.51 C	Filter	16
Pressure	977.47 mB	Last Zero Value	Default ppm
Average Current	1041 uA	Pressure Comp	984 mB
Relative Humidity	42.12 %RH	Hours Ran	806
Absolute Humidity	7.07 g/m ³		

CO₂ measurements are filtered by default. The digital filter value can be varied between 1-256. If set to 1, there is no digital filtering. The default value is 16. Reducing the digital filtering increases sensor response rate at the expense of measurement noise.

SENSOR COMMUNICATIONS

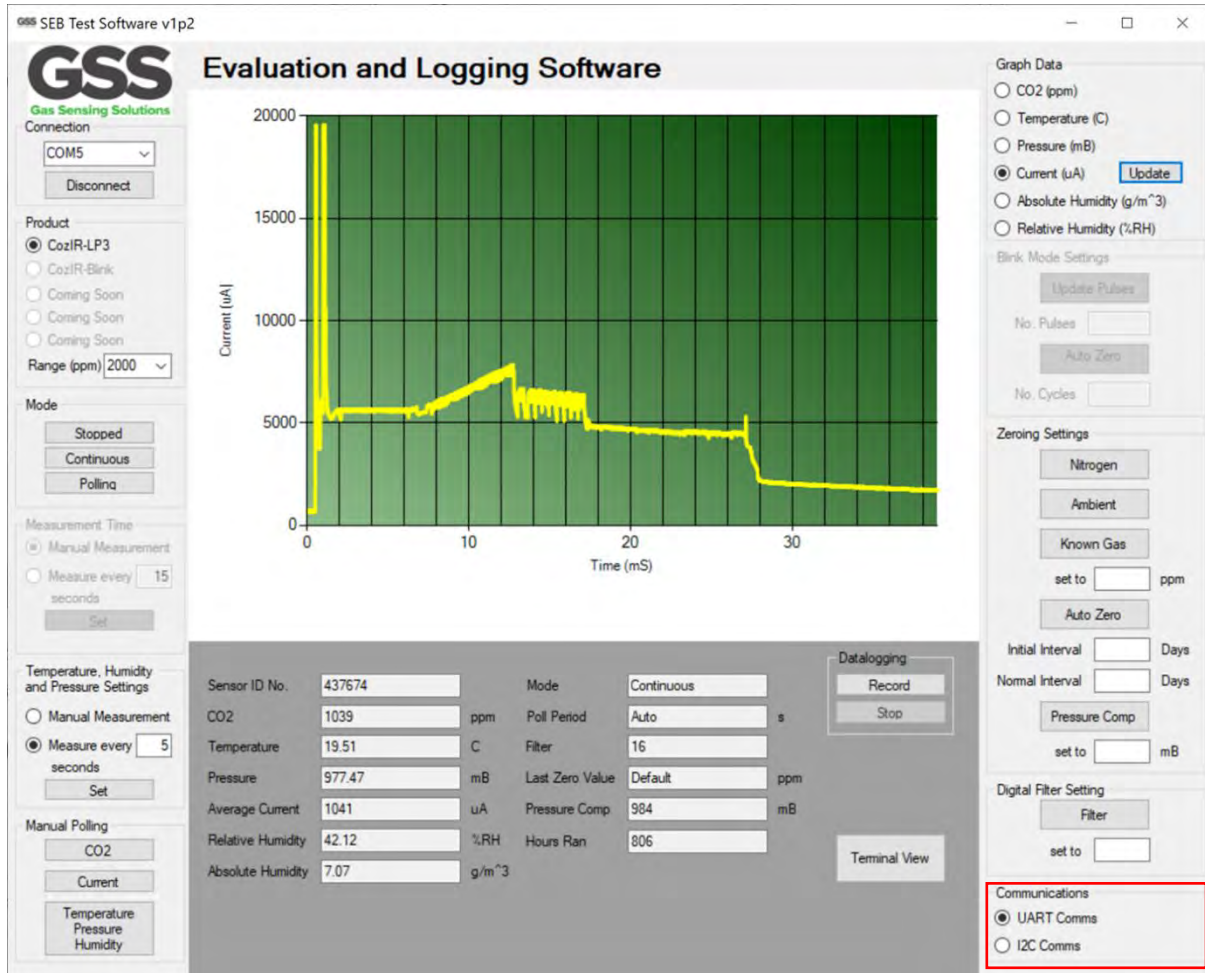

GSS SEB Test Software v1p2
Evaluation and Logging Software

Graph Data

- CO2 (ppm)
- Temperature (C)
- Pressure (mB)
- Current (uA) Update
- Absolute Humidity (g/m³)
- Relative Humidity (%RH)

Blink Mode Settings

Update Pulses

No. Pulses

Auto Zero

No. Cycles

Zeroing Settings

Nitrogen

Ambient

Known Gas

set to ppm

Auto Zero

Initial Interval Days

Normal Interval Days

Pressure Comp

set to mB

Digital Filter Setting

Filter

set to

Communications

- UART Comms
- I2C Comms

Sensor ID No.	437674	Mode	Continuous
CO2	1039 ppm	Poll Period	Auto s
Temperature	19.51 C	Filter	16
Pressure	977.47 mB	Last Zero Value	Default ppm
Average Current	1041 uA	Pressure Comp	984 mB
Relative Humidity	42.12 %RH	Hours Ran	806
Absolute Humidity	7.07 g/m ³		

The sensor has two control interface modes. To ensure the sensor behaviour is representative of real-world use, the evaluation board microprocessor will communicate with the sensor in either UART or I²C mode dependent on this setting. To set the interface mode, click on the appropriate dialogue box.

DATA DISPLAY

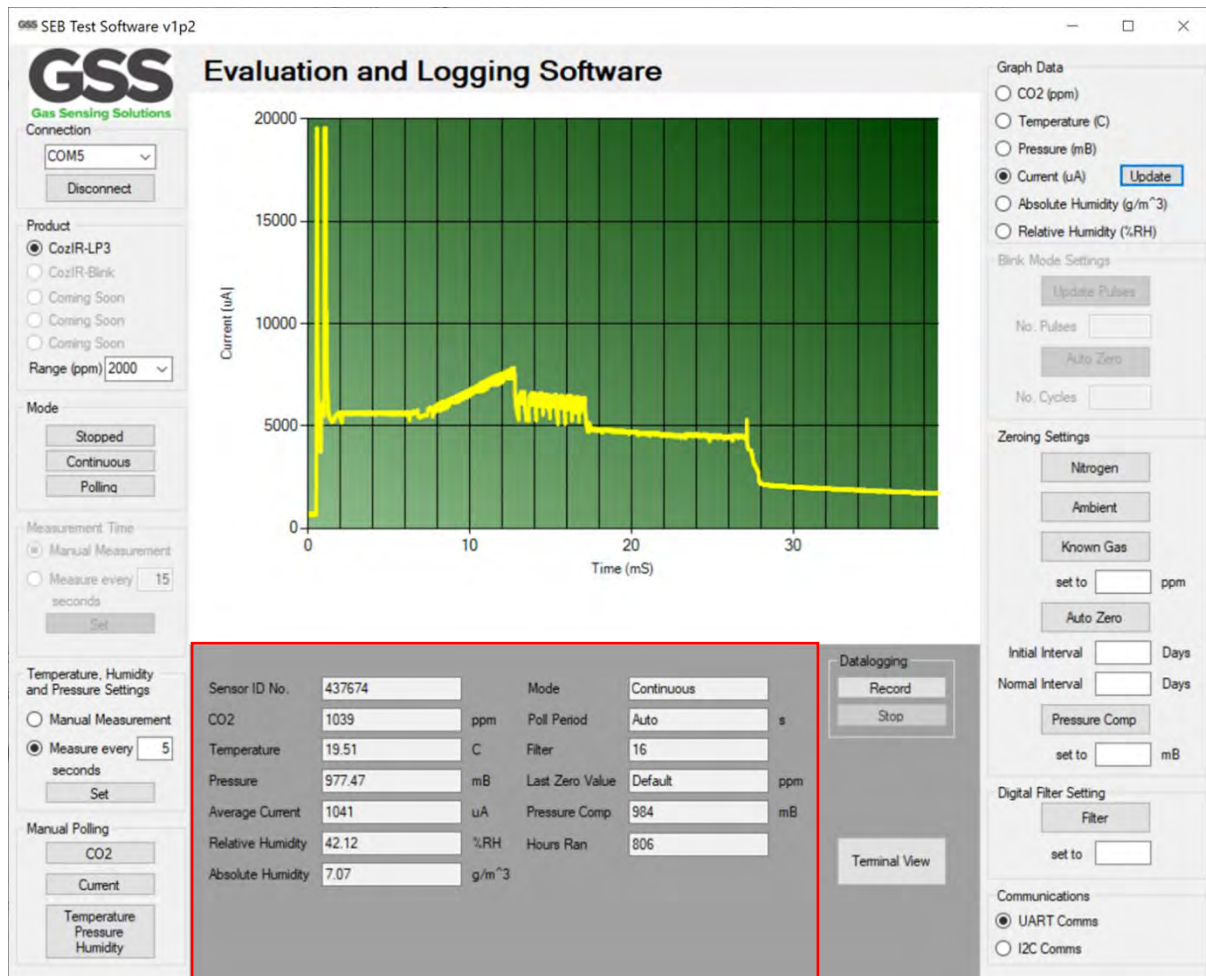

Essential sensor data is displayed numerically in the lower half of the user interface.

Sensor Data Type	Description	Units
Sensor ID No.	Unique sensor ID	N/A
CO2	CO ₂ concentration	ppm
Temperature	Ambient temperature	°C
Pressure	Ambient pressure	mbar
Average Current	Current drawn by the sensor in a measurement cycle – see description for more details.	uA
Relative Humidity	Ambient relative humidity	%RH
Absolute Humidity	Ambient absolute humidity	grams per cubic metre

This data is updated depending on the measurement mode of the sensors.

Sensor Data Type	Description	Units
Mode	Measurement mode	
Poll Period	Measurement update period	Seconds
Filter	Digital filter setting	Decimal
Last Zero Value	Value used to re-zero the sensor	ppm
Pressure Comp	Pressure value used by CO ₂ sensor	mbar
Hours Ran	Number of hours sensor has been powered up	Decimal

This data is static and represents the configuration of the CO₂ sensor.

DATALOGGING

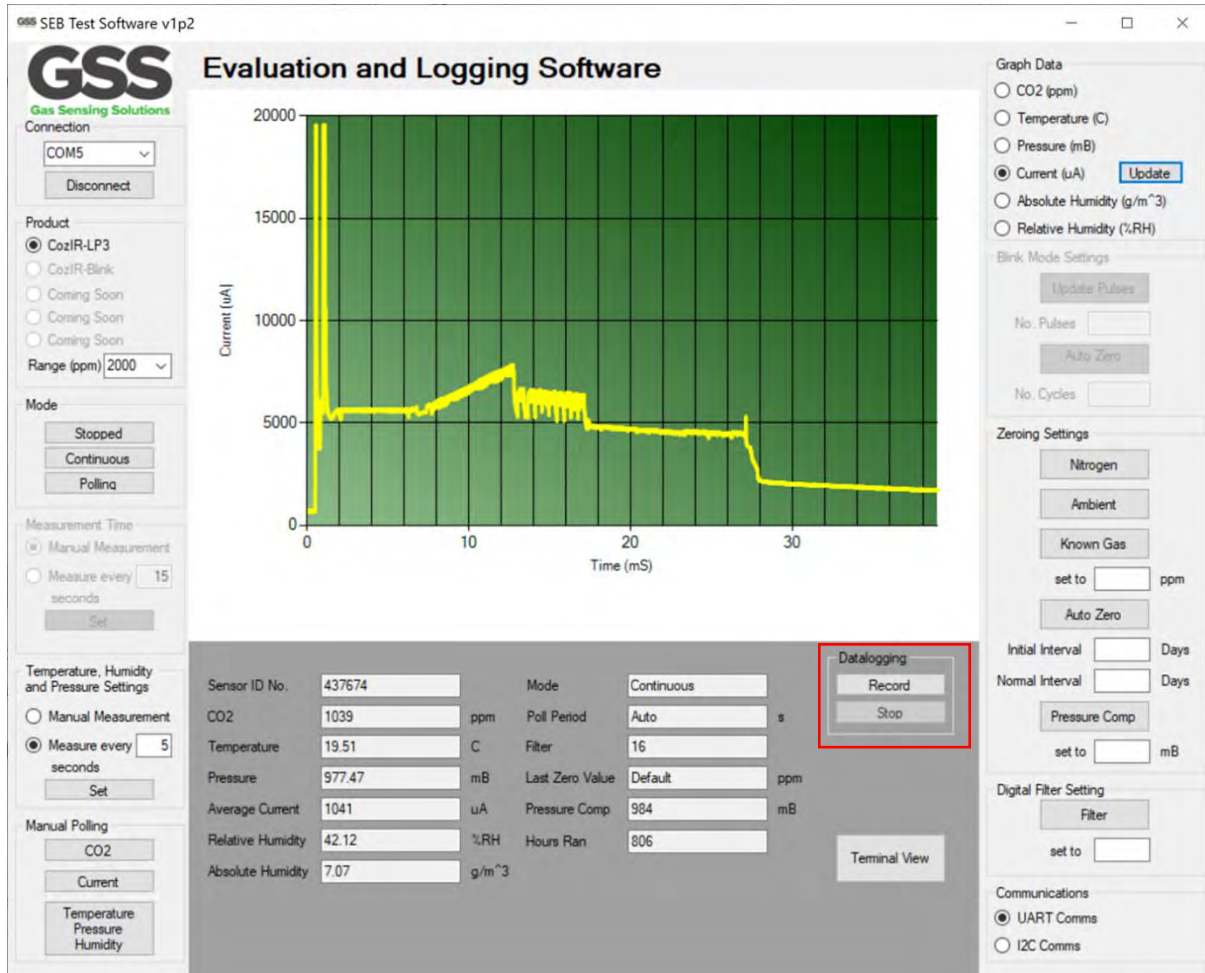

GSS SEB Test Software v1p2

Evaluation and Logging Software

Connection: COM5

Product: CozIR-LP3

Mode: Stopped

Measurement Time: Manual Measurement

Temperature, Humidity and Pressure Settings: Measure every 5 seconds

Sensor ID No.	437674	Mode	Continuous
CO2	1039 ppm	Poll Period	Auto s
Temperature	19.51 C	Filter	16
Pressure	977.47 mB	Last Zero Value	Default ppm
Average Current	1041 uA	Pressure Comp	984 mB
Relative Humidity	42.12 %RH	Hours Ran	806
Absolute Humidity	7.07 g/m ³		

Datalogging: Record, Stop

CO₂ and other sensor data can be recorded. To initiate the recording process, click 'Record'. To stop the recording process, click 'Stop'.

Clicking on 'Record' brings up the following screen.

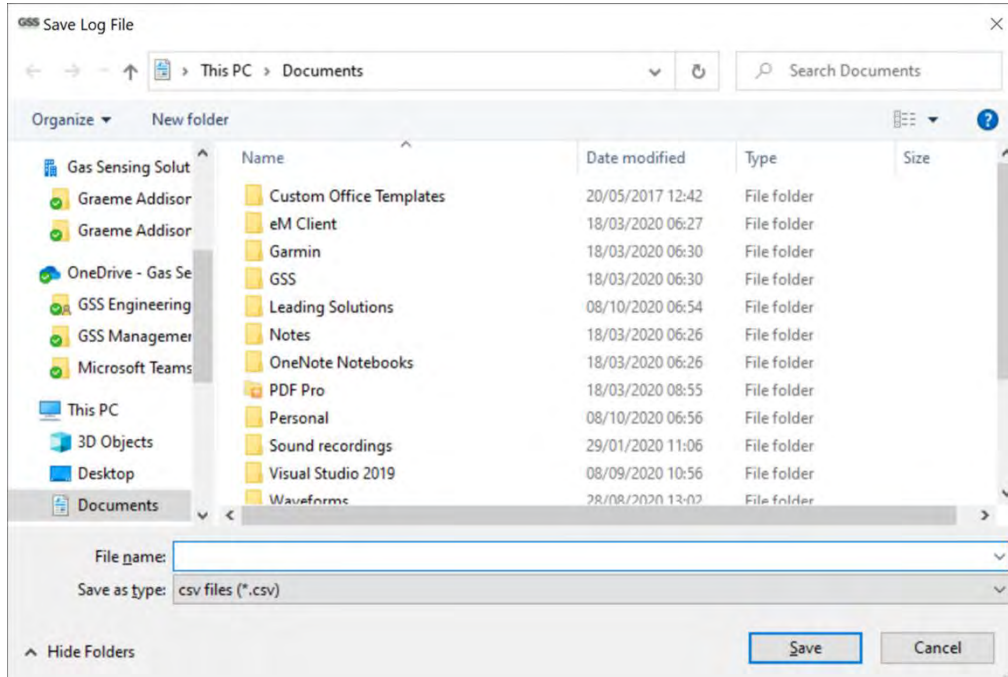

The user can select where the file is stored and directly type in the file name.

The data will be recorded as a .csv file that can subsequently be opened in a spreadsheet program. The sensor data will be timestamped, allowing easy analysis of all environmental parameters. The measurement period for each sensor type follows the settings on the user interface.

Recorded by GSS Sensor Evaluation Board					
16/11/2020 13:02					
437674					
Timestamp	CO2 ppm	Temperature C	Pressure mB	%RH	AH g/m ³
16/11/20 13:02:53.729	460				
16/11/20 13:02:54.834					
16/11/20 13:02:55.218	453				
16/11/20 13:02:56.338					
16/11/20 13:02:56.723	459				
16/11/20 13:02:56.739		23.92	1002.33	43.64	9.45
16/11/20 13:02:57.827					
16/11/20 13:02:58.228	466				
16/11/20 13:02:59.332					
16/11/20 13:02:59.733	474				
16/11/20 13:03:00.838					
16/11/20 13:03:01.222	471				
16/11/20 13:03:01.349		23.92	1002.3	43.66	9.45
16/11/20 13:03:02.342					
16/11/20 13:03:02.727	468				
16/11/20 13:03:03.847					
16/11/20 13:03:04.232	479				
16/11/20 13:03:05.337					
16/11/20 13:03:05.737	490				
16/11/20 13:03:06.361		23.93	1002.34	43.66	9.46

The above table shows the CO₂ sensor ID437674, with different data recorded at different rates.

TERMINAL VIEW

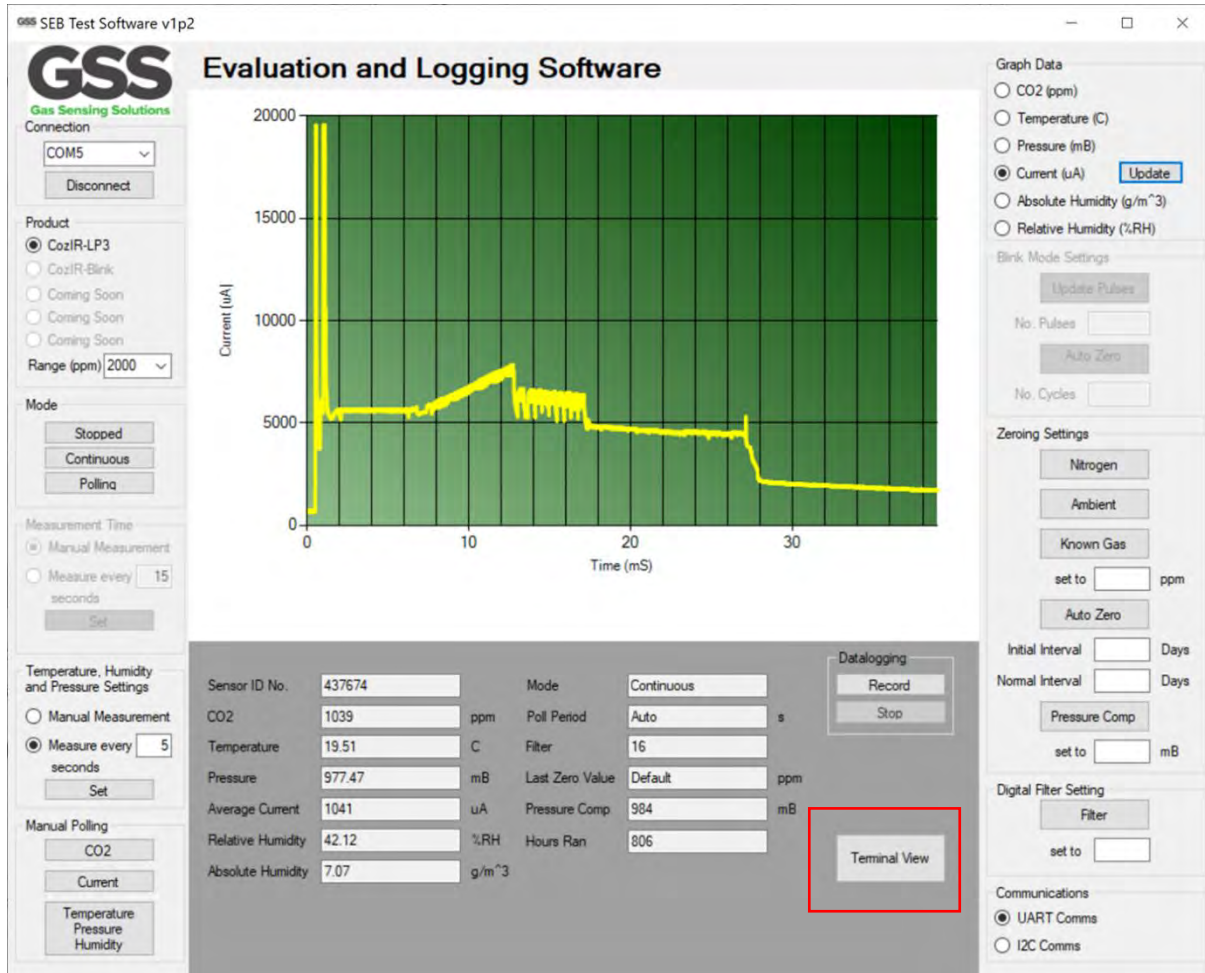

The screenshot shows the 'Evaluation and Logging Software' interface. A central graph plots 'Current (uA)' on the y-axis (0 to 20000) against 'Time (mS)' on the x-axis (0 to 30). The graph shows a sharp initial spike followed by a steady rise and then a gradual decline. On the right side, the 'Graph Data' section has 'Current (uA)' selected with a radio button and an 'Update' button next to it. At the bottom of the interface, a 'Terminal View' button is highlighted with a red rectangular box. The interface also includes various settings panels on the left and right, such as 'Connection', 'Product', 'Mode', 'Measurement Time', 'Temperature, Humidity and Pressure Settings', 'Manual Polling', 'Datalogging', 'Blink Mode Settings', 'Zeroing Settings', 'Digital Filter Setting', and 'Communications'.

Access to all CO₂ sensor functions and register settings are available to the user using the Terminal View. Terminal View allows the user to read and write directly to the CO₂ sensor.

In the Terminal View, the user can reset the sensor if required by clicking on the 'Reset' button. This toggles the state of the sensor PWR_ON pin.

TERMINAL VIEW – UART READ

To open the terminal window for UART communications, first ensure that 'UART Comms' has been selected under the 'Communications' menu.

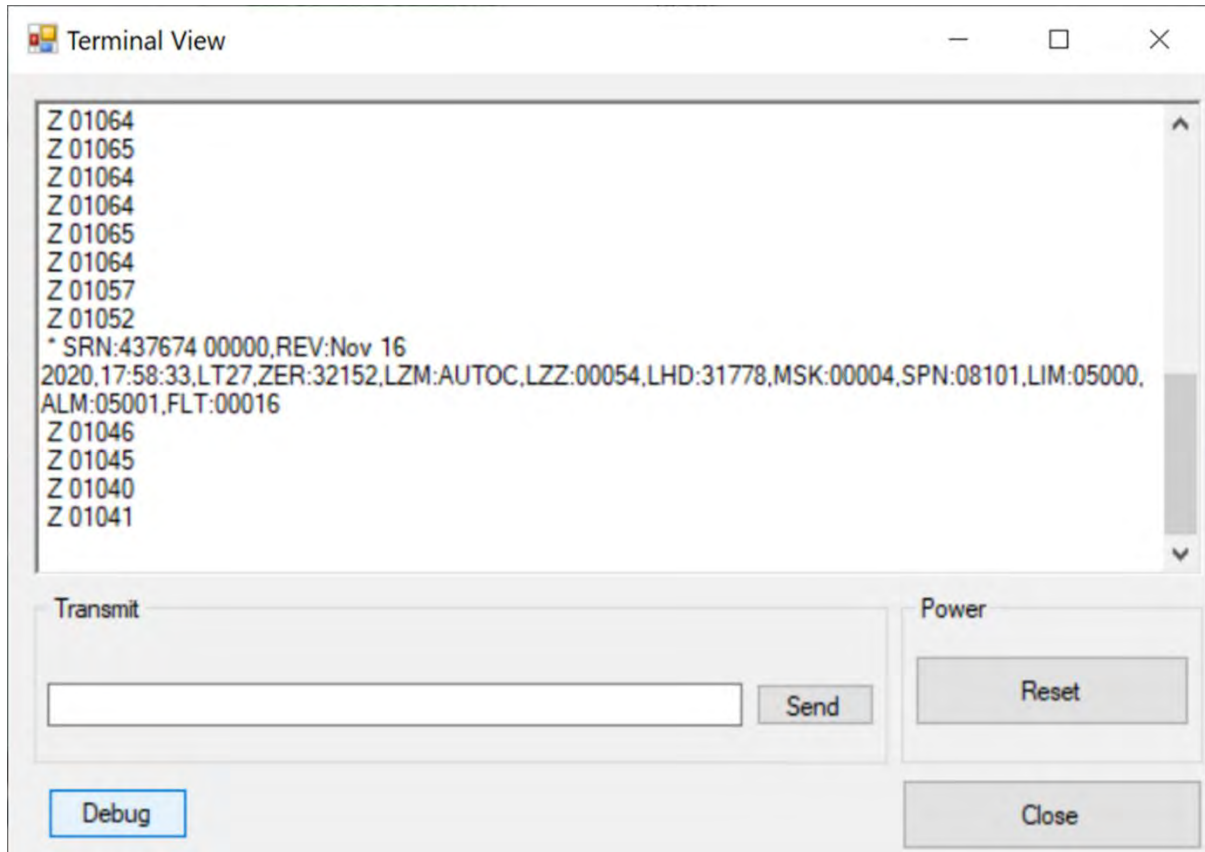

To read a value, write the command into the dialogue box, and click 'Send'. In this example, the Command '*' is shown. It automatically returns the information shown in the Terminal View.

By pressing the 'Debug' button, a command is sent to return the sensor settings as above. This returns information on the state of the sensor, including sensor ID (437674).

TERMINAL VIEW – UART WRITE

Write the command into the dialogue box and click 'Send'. In this example, the X Command is shown. X is the command to zero the sensor in a known gas concentration, in this case 1000ppm. Sending a command followed by an integer (X 1000 in this case) will write the value into the appropriate register. The sensor will respond with a variable decimal value.

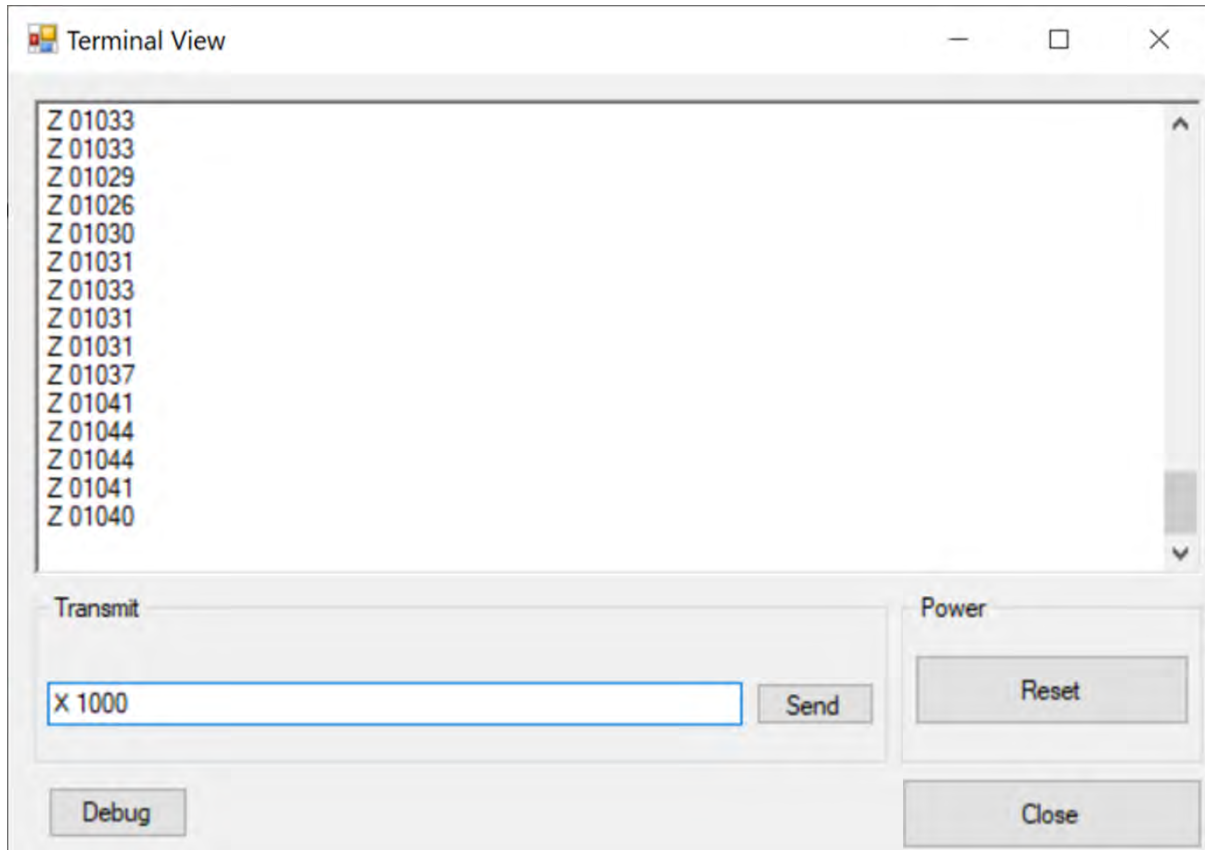

TERMINAL VIEW – I²C WRITE

To open the terminal window for I²C communications, first ensure that 'I²C Comms' has been selected under the 'Communications' menu.

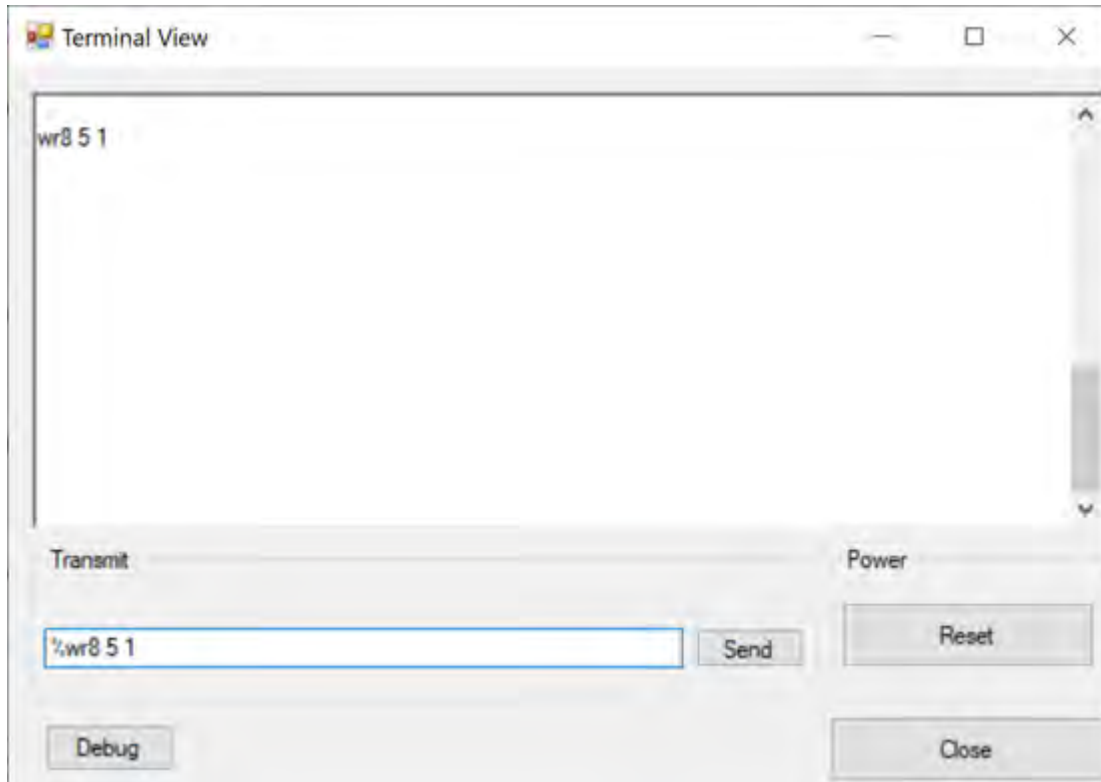

To write to an I²C register, the instruction must be formatted correctly.

Writes are formatted as “%wr”, followed by the number of bits to write, followed by the register number in decimal, followed by the decimal value to write to the register.

For example: “%wr8 5 1” will write the value 1 (as an 8-bit word) to register 5, which will zero the sensor in ambient conditions as per the datasheet.

Note the debug button does not function in I²C mode.

TERMINAL VIEW – I²C READ

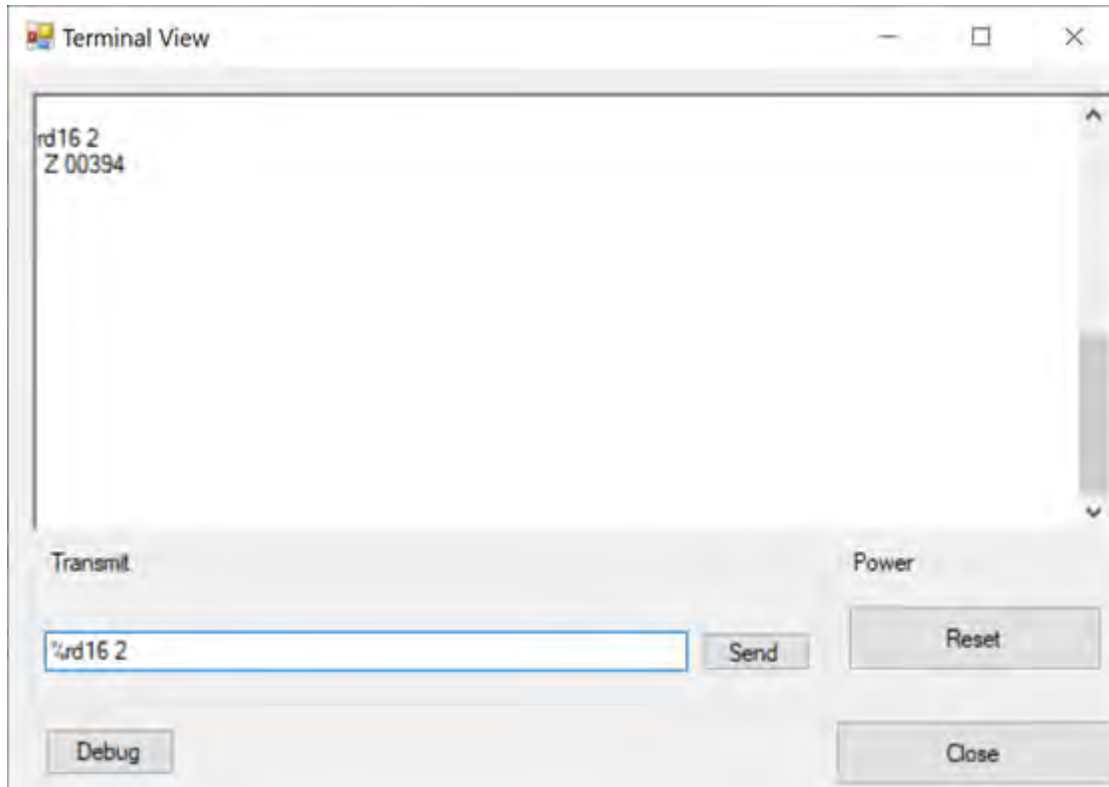

To read from an I2C register, the instruction is formatted as “%rd” followed by the number of bits to read as noted in the datasheet, followed by the register number in decimal.

For example: “%rd16 2” will read 16 bits from register 2 which in this case will return the CO₂ value in ppm.

The “%” in the I²C commands denotes to the evaluation board that a special command that must be pre-processed before passing on to the sensor. If the interface is set to I²C mode, and if the % is missing, the evaluation board assume the command is a UART command and sending it on to the sensor will return a timeout.

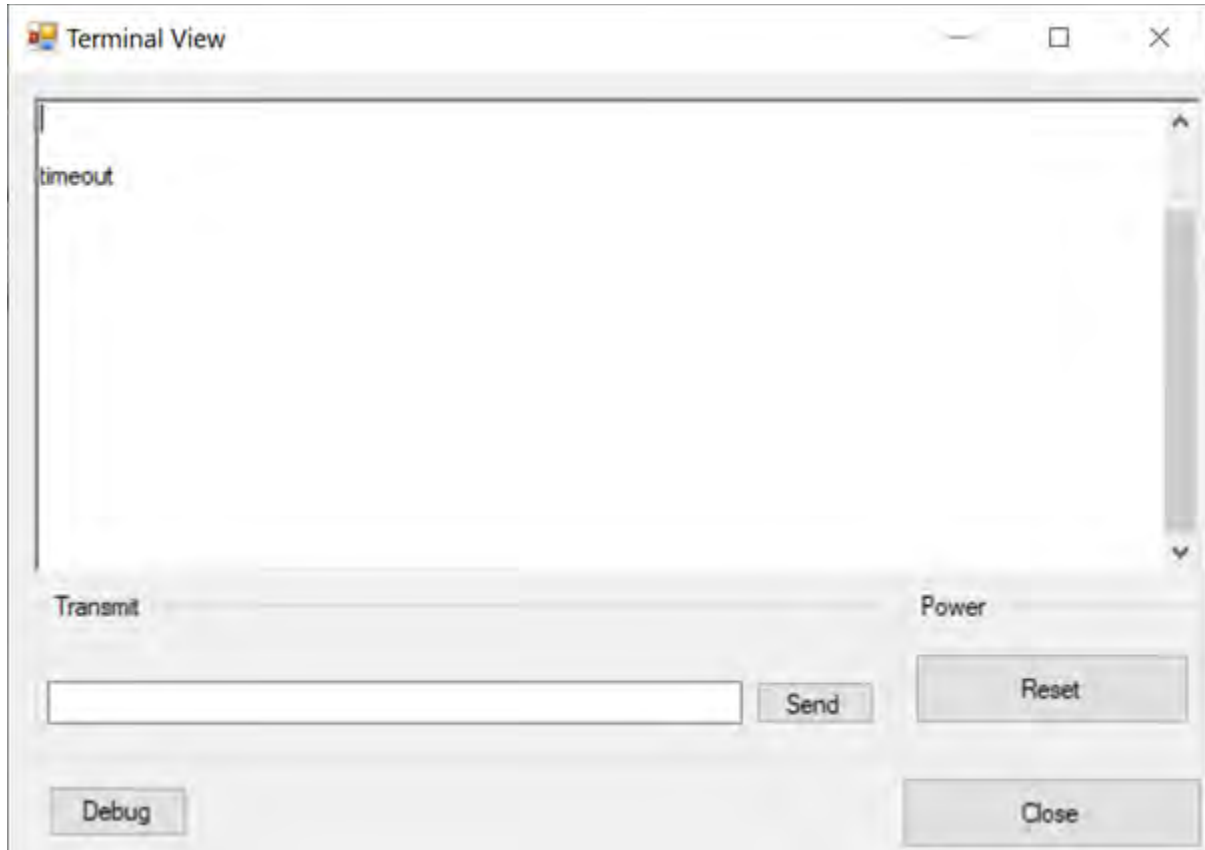

MECHANICAL DIAGRAM

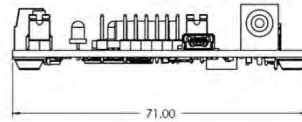
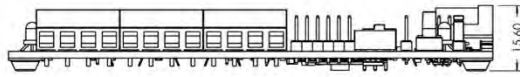
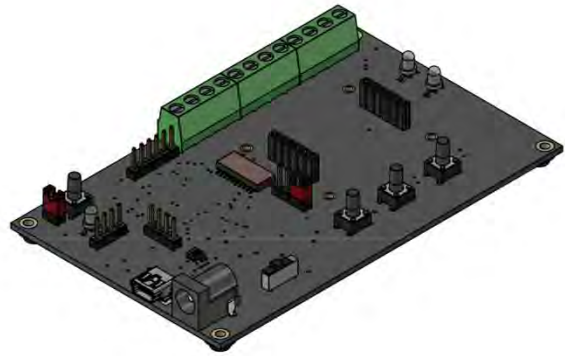
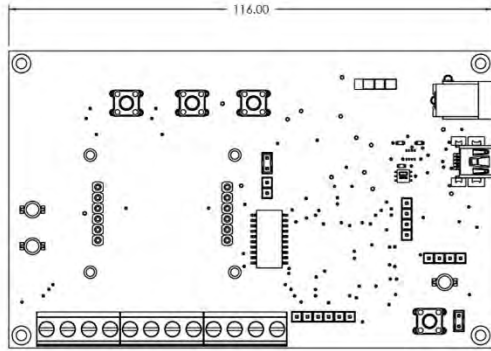

IMPORTANT NOTICE

Gas Sensing Solutions Ltd. (GSS) products and services are sold subject to GSS's terms and conditions of sale, delivery and payment supplied at the time of order acknowledgement. GSS warrants performance of its products to the specifications in effect at the date of shipment. GSS reserves the right to make changes to its products and specifications or to discontinue any product or service without notice.

Customers should therefore obtain the latest version of relevant information from GSS to verify that the information is current. Testing and other quality control techniques are utilised to the extent GSS deems necessary to support its warranty. Specific testing of all parameters of each device is not necessarily performed unless required by law or regulation. In order to minimise risks associated with customer applications, the customer must use adequate design and operating safeguards to minimise inherent or procedural hazards. GSS is not liable for applications assistance or customer product design. The customer is solely responsible for its selection and use of GSS products. GSS is not liable for such selection or use nor for use of any circuitry other than circuitry entirely embodied in a GSS product.

GSS products are not intended for use in life support systems, appliances, nuclear systems or systems where malfunction can reasonably be expected to result in personal injury, death or severe property or environmental damage. Any use of products by the customer for such purposes is at the customer's own risk.

GSS does not grant any licence (express or implied) under any patent right, copyright, mask work right or other intellectual property right of GSS covering or relating to any combination, machine, or process in which its products or services might be or are used. Any provision or publication of any third party's products or services does not constitute GSS's approval, licence, warranty or endorsement thereof. Any third party trademarks contained in this document belong to the respective third-party owner.

Reproduction of information from GSS datasheets is permissible only if reproduction is without alteration and is accompanied by all associated copyright, proprietary and other notices (including this notice) and conditions. GSS is not liable for any unauthorised alteration of such information or for any reliance placed thereon.

Any representations made, warranties given, and/or liabilities accepted by any person which differ from those contained in this datasheet or in GSS's standard terms and conditions of sale, delivery and payment are made, given and/or accepted at that person's own risk. GSS is not liable for any such representations, warranties or liabilities or for any reliance placed thereon by any person.

ADDRESS

Gas Sensing Solutions Ltd.
Grayshill Road
Cumbernauld
G68 9HQ
United Kingdom



USER GUIDE

REVISION HISTORY

DATE	RELEASE	DESCRIPTION OF CHANGES	PAGES
21/07/2020	1.0	First revision	All
20/10/2020	1.1	Full first draft	All
13/11/2020	1.2	Updates	All
25/11/2020	1.3	Final UI	All
5/12/2020	1.4	First formal release	All
15/15/2020	1.5	Mechanical Diagram and Pin Out Description	P.37
17/12/2020	1.6	Corrected External Variable Supply table	P.10